

Safe Work Practices on High Voltage Overhead Lines

Summary

This document supports the Power System Safety Rules and its requirements under Overhead Lines and Equipment - Category 6 and describe safe work practices to be followed for the treatment of hazardous situations.

It applies to work practices on all overhead lines and associated apparatus including overhead lines within a substation.

Document Control

Revision no:	3	HP TRIM no:	D2004/10689	Approval/ Review date:	9 April 2020
Business function:	Manage Health And Safety			Document type:	Corporate Work Instruction
Process owner:	Head of HSE				
Related Procedure/s:	Power System Safety Rules Access for Work on High Voltage Overhead Lines				
Author:	Kitchener Morris, PSSR Manager				
Reviewers:	Anthony Armstrong; Acting Senior Program Manager – Transmission Lines and Cables Martin Hoarau; Transmission Lines and Cables Manager Andrew Swaffield; Corrective Works Delivery Manager Darren Rickard; Works Leader Kevin Burke; Transmission Lines and Cables Officer Joshua Jones; Technical Trainer Krista-Lee Fogarty, Head of HSE				
Approver:	Michael Gatt, EM, Works Delivery				

Warning: A printed copy of this document may not be the current version. Please refer to the Wire to verify the current version.

Contents

1. Purpose	4
2. Scope	4
2.1 Document Location	4
3. Introduction	4
4. Overhead Line Hazardous Situations	6
5. Safe Work Practices	9
5.1 Identification of High Voltage Feeders	9
5.1.1 General Procedures for Work on Double Circuit Lines	9
5.1.2 Identifying the Live Circuit on a Double Circuit Tower	10
5.1.3 Identifying the Live Circuit on a Double Circuit Pole	11
5.2 Persons to Keep Clear of Equipment	12
5.3 Earthing Plans	12
5.4 Engineer's Assessment	12
5.5 Persons Working at Ground Level	13
5.5.1 Persons Working at Ground Level (Other than on Conductors)	13
5.5.2 Persons Working on Conductors or Overhead Earthwires at Ground Level	13
5.5.3 Safeguards for Persons While Working at Ground Level	13
5.5.4 Handling Conductors or Earthwires at Ground Level (Insulated Work Methods)	16
5.6 Persons Working Aloft	18
5.6.1 Bonded Work Spaces Aloft	18
5.6.2 Bonded Work Space – Steel Tower	18
5.6.3 Bonded Work Space – Wood Pole Structure	19
5.6.4 Bonded Work Space – Elevated Work Platform	19
5.6.5 Insulated Working from an Insulated Elevating Work Platform	20
5.7 Making or Breaking Connections on High Voltage Overhead Lines	21
5.7.1 Application of a Bridging Lead	21
5.8 Large Work Sites	22
5.9 Stringing an Overhead Line Parallel to an In-Service Line	22
5.9.1 Work Areas and Equipment	22
5.9.2 Standard Safeguards to be applied for Stringing Operations	23
5.10 Stringing Conductor on Landing Span to HV Substations	25
5.10.1 Standard Safeguards	25
5.10.2 Outline of Procedure for Stringing landing Spans	25
5.10.3 Special Circumstances	28
5.11 Testing of HV Overhead Lines - Safeguards for Use of Test Instruments	28
5.12 Work on Structure Earthing Systems	30
6. Accountability	30
7. Implementation	30

Warning: A printed copy of this document may not be the current version. Please refer to the Wire to verify the current version.

8. Monitoring and Review	31
9. Change from previous version	31
10. References	31
11. Attachments	31

SUPERSEDED

Warning: A printed copy of this document may not be the current version. Please refer to the Wire to verify the current version.

1. Purpose

This document supports the Power System Safety Rules and its requirements under Overhead Lines and Equipment - Category 6 and describe safe work practices to be followed for the treatment of hazardous situations.

2. Scope

This document applies to work practices on all overhead lines and associated apparatus including overhead lines within a substation.

2.1 Document Location

Block diagram showing location of document in relation to other PSSR procedures.

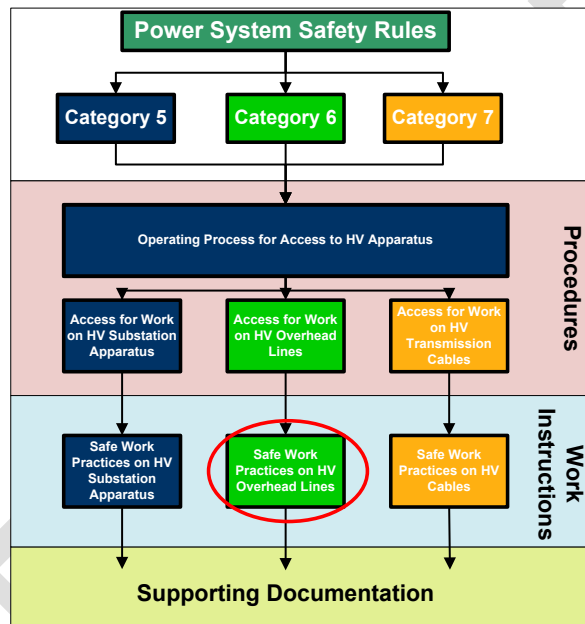

3. Introduction

This document was developed as a guide to assist in selecting the correct safe work practices to be used when performing work on overhead lines. Work may only commence on an overhead line when it has been made safe for work and an Access Authority has been issued.

The safe work practices contained within this document protect workers from the hazardous occurrences or effects that can develop on or around overhead lines and their support structures, including:

- > Lightning;
- > Induced voltages and currents;
- > Transfer voltages;
- > Voltage gradients;
- > Line energising; and
- > Neutral and earthing system currents.

This document sets out a range of hazardous situations, the controls (safeguards) to be implemented and describes the safe work practices which must be observed. The possible safe work practices are referenced for each situation.

Warning: A printed copy of this document may not be the current version. Please refer to the Wire to verify the current version.

This document should be read in conjunction with Portable Earthing of High Voltage Conductors. This document indicates when various practices should be used and indicates what hardware should be used when implementing the nominated practices.

It is the responsibility of all workers engaged in work on high voltage overhead lines to follow all the safe work practices applicable to the work.

These safe work practices are to be used in conjunction with TransGrid's Health and Safety Risk Assessment process. The risk assessment process may identify that additional controls are required for particular tasks and situations.

SUPERSEDED

Warning: A printed copy of this document may not be the current version. Please refer to the Wire to verify the current version.

4. Overhead Line Hazardous Situations

The following table lists situations encountered when working on or in the vicinity of overhead lines and controls to be implemented.

Situations	Hazards	Controls	Reference
Conductors at or near ground (large area or short time)	Transferred Earth Potentials	Insulated method	Section 5.2 - Persons to Keep Clear of Equipment Section 5.4 - Engineer's Assessment Section 5.5 - Persons Working at Ground Level Section 5.8 - Large Work Sites Error! Reference source not found. Error! Reference source not found.
Conductors at or near ground (small work area or long time)	Transferred Earth Potentials	Bonded workspace	Section 5.4 - Engineer's Assessment Section 5.5 - Persons Working at Ground Level
Making/ Breaking connections (Conductor + Earth wire)	Transferred Earth Potentials	Insulated until connected, then bonded. Bridging leads applied using insulated methods.	Section 5.1 - Identification of High Voltage Feeders Section 5.3 - Earthing Plans Section 5.6 - Persons Working Aloft Section 5.7 - Making or Breaking Connections on High Voltage Overhead Lines
Making connections on landing spans to HV Substations	Transferred Earth Potentials	Insulated until connected, then bonded. Bridging leads applied using insulated methods.	Section 5.1 - Identification of High Voltage Feeders Section 5.4 - Engineer's Assessment Section 5.6 - Persons Working Aloft Section 5.7 - Making or Breaking Connections on High Voltage Overhead Lines Section 5.10 - Stringing Conductor on Landing Span to HV Substations

Warning: A printed copy of this document may not be the current version. Please refer to the Wire to verify the current version.

Situations	Hazards	Controls	Reference
Making/Breaking overhead earth wire connections.	Current in Earth System	Bridging leads applied using insulated tools. (Hot connections maybe an issue)	Section 5.1 - Identification of High Voltage Feeders Section 5.6 - Persons Working Aloft Section 5.7 - Making or Breaking Connections on High Voltage Overhead Lines
Making/Breaking Connections to an out of service line near or parallel to in service lines	Induction	Insulated until connected, then bonded. Bridging leads applied using insulated earth application handle.	Section 5.1 - Identification of High Voltage Feeders Section 5.3 - Earthing Plans Section 5.4 - Engineer's Assessment Section 5.6 - Persons Working Aloft Section 5.7 - Making or Breaking Connections on High Voltage Overhead Lines Section 5.9 - Stringing an Overhead Line Parallel to an In-Service Line
Stringing an Overhead Line Parallel to an In-Service Line	Induction	Bonded workspace & rolling earths.	Section 5.9 - Stringing an Overhead Line Parallel to an In-Service Line Appendix C - - Rolling Earths
Working at ground level around structures	Voltage Gradients	Avoid unnecessary contact. Work insulated if repeated or prolonged contact.	Section 5.2 - Persons to Keep Clear of Equipment
Working with metallic winch ropes.	Voltage Gradients	Work insulated or bonded if prolonged contact/work.	Section 5.9 - Stringing an Overhead Line Parallel to an In-Service Line
Working around mobile plant earthed to tower	Voltage Gradients	Work insulated or bonded if prolonged contact/work.	Section 5.2 - Persons to Keep Clear of Equipment
Working around perimeter of large bonded work areas	Voltage Gradients	Bunting barrier and insulated approach.	Section 5.5.3.1 - Provision of Insulated Access to Bonded Work Spaces at Ground Level

Warning: A printed copy of this document may not be the current version. Please refer to the Wire to verify the current version.

Situations	Hazards	Controls	Reference
Trees (dry) fallen on conductors	Voltage Gradients	Insulated tools.	Error! Reference source not found. Error! Reference source not found.
HV Transmission Line Structure Earth Systems	Induction, Current in Earth Wire, Transferred Earth Potentials	Bridging, Insulated Tools	Section 5.12 - Work on Structure Earthing Systems Safe Work Practices for Bridging of Structure Earthing Systems

SUPERSEDED

Warning: A printed copy of this document may not be the current version. Please refer to the Wire to verify the current version.

5. Safe Work Practices

Safe work practices are applicable to all overhead line working situations and are to be used (as applicable) for all overhead line work.

It is essential when developing safe working procedures to carefully assess the possibility of hazardous voltage rises occurring at the work site and where appropriate, give consideration to the following basic safe working practices and safeguards.

These safeguards (controls) are to be used in conjunction with TransGrid's Health and Safety Risk Assessment process.

5.1 Identification of High Voltage Feeders

High Voltage Overhead Line structures are identified by a feeder identification number and structure identification numbers e.g. 30/247 where 30 refers to the overhead line number and 247 refers to the structure number.

Double circuit towers have an identification number for each circuit, clearly marked on the appropriate legs of the tower, so that the circuit can be positively identified. PSSR 6.4.1 (d) states that:

Coloured flags shall be draped from suitable locations on multi-circuit High Voltage overhead lines structures using approved methods to identify the conductors that are to be regarded as live.

5.1.1 General Procedures for Work on Double Circuit Lines

For persons working aloft it is essential to identify the circuit on which work is to be carried out. Identification is assisted by the presence of Access Authority Earths on the isolated circuit.

The procedures detailed below have been developed to minimise the hazard to persons working at ground level as well as providing additional indication of live conductors to persons working aloft:

- (a) Ensure that the overhead line description given by the Controller agrees with that on the Request for Access and the identification number on the overhead line structure.
- (b) After the circuit has been proved de-energised and Access Authority Earths applied, the in-service side of the double circuit structure is to be identified by a barrier of red flag bunting, set up to extend approximately 10 metres from, and on each side of the structure running parallel to the conductors. Red flags or bunting shall also be draped at the junction of the structure body and each of the three cross-arms of the live circuit in order to clearly indicate the live circuit. Where the climbing pegs and ladder support are on the in-service side of the structure, an opening may be provided in the barrier to allow access to the foot of the ladder.
- (c) All plant and equipment on the ground and aloft are to be confined to the side of the structure on which work is being carried out. Where this is impracticable the person in charge of the work shall nominate a person to be a safety observer.
- (d) All conducting fall ropes from the structure to the ground shall be brought through snatch blocks near ground level on the side of the structure on which work is being performed.

Sections 5.1.2 and 5.1.3 show the arrangement of the red bunting and/or flags on double circuit steel tower and pole structures.

Insets to these sketches show the arrangement of red flag bunting which may be used where the nature of the terrain makes it impracticable to set out the barrier of red flag bunting indicated below.

Warning: A printed copy of this document may not be the current version. Please refer to the Wire to verify the current version.

5.1.2 Identifying the Live Circuit on a Double Circuit Tower

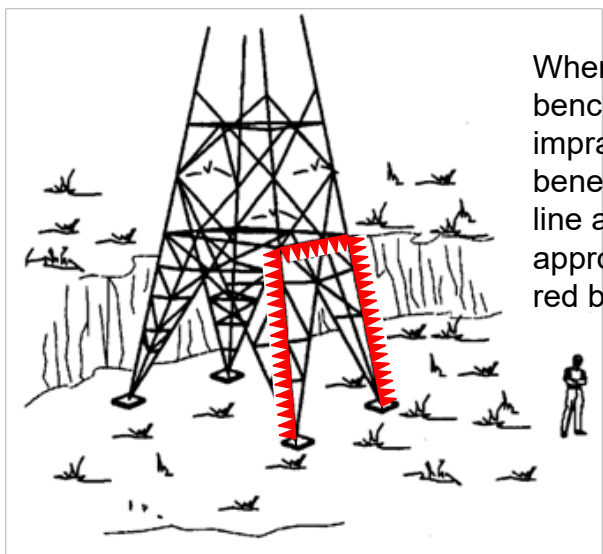
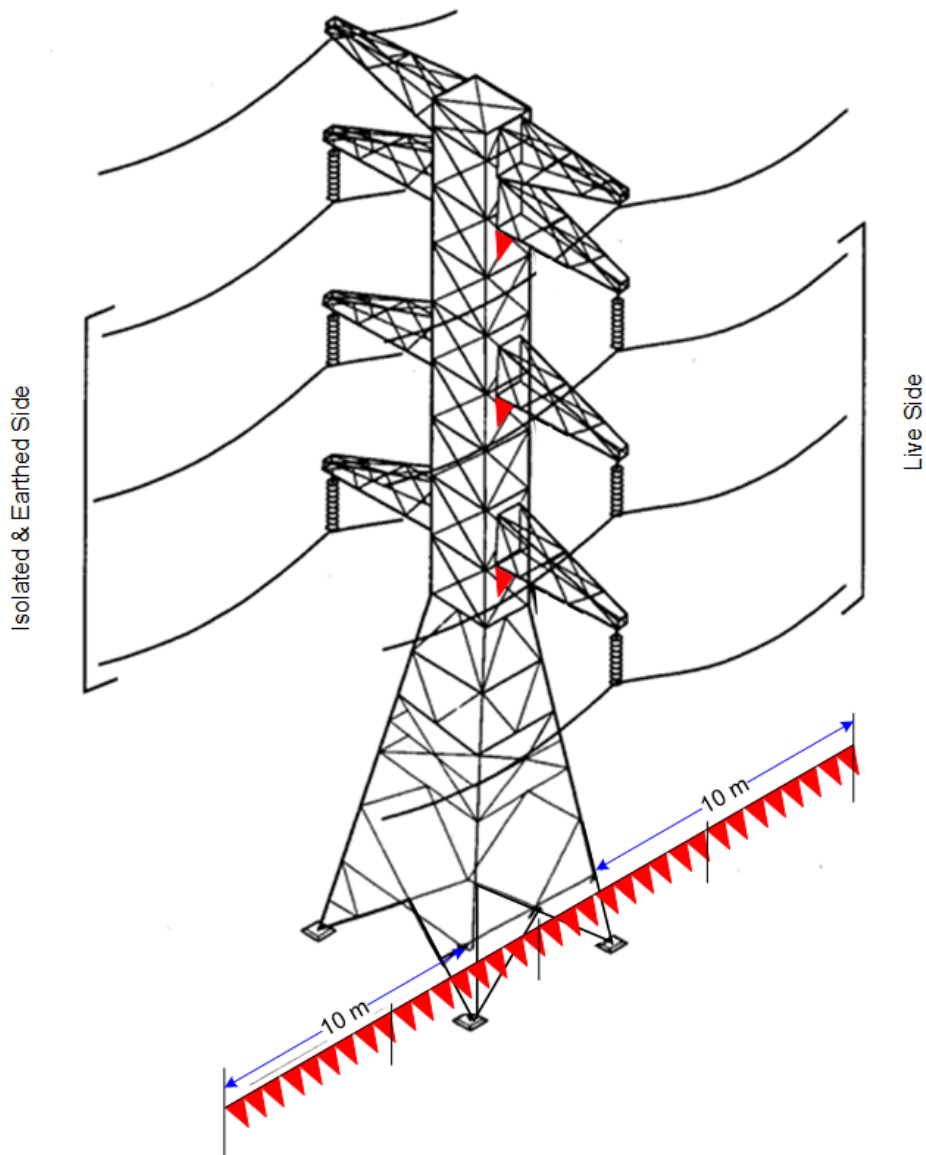

Where the cut for tower bench makes it impracticable to work beneath the isolated line at ground level, an appropriate position for red bunting is shown

Warning: A printed copy of this document may not be the current version. Please refer to the Wire to verify the current version.

5.1.3 Identifying the Live Circuit on a Double Circuit Pole

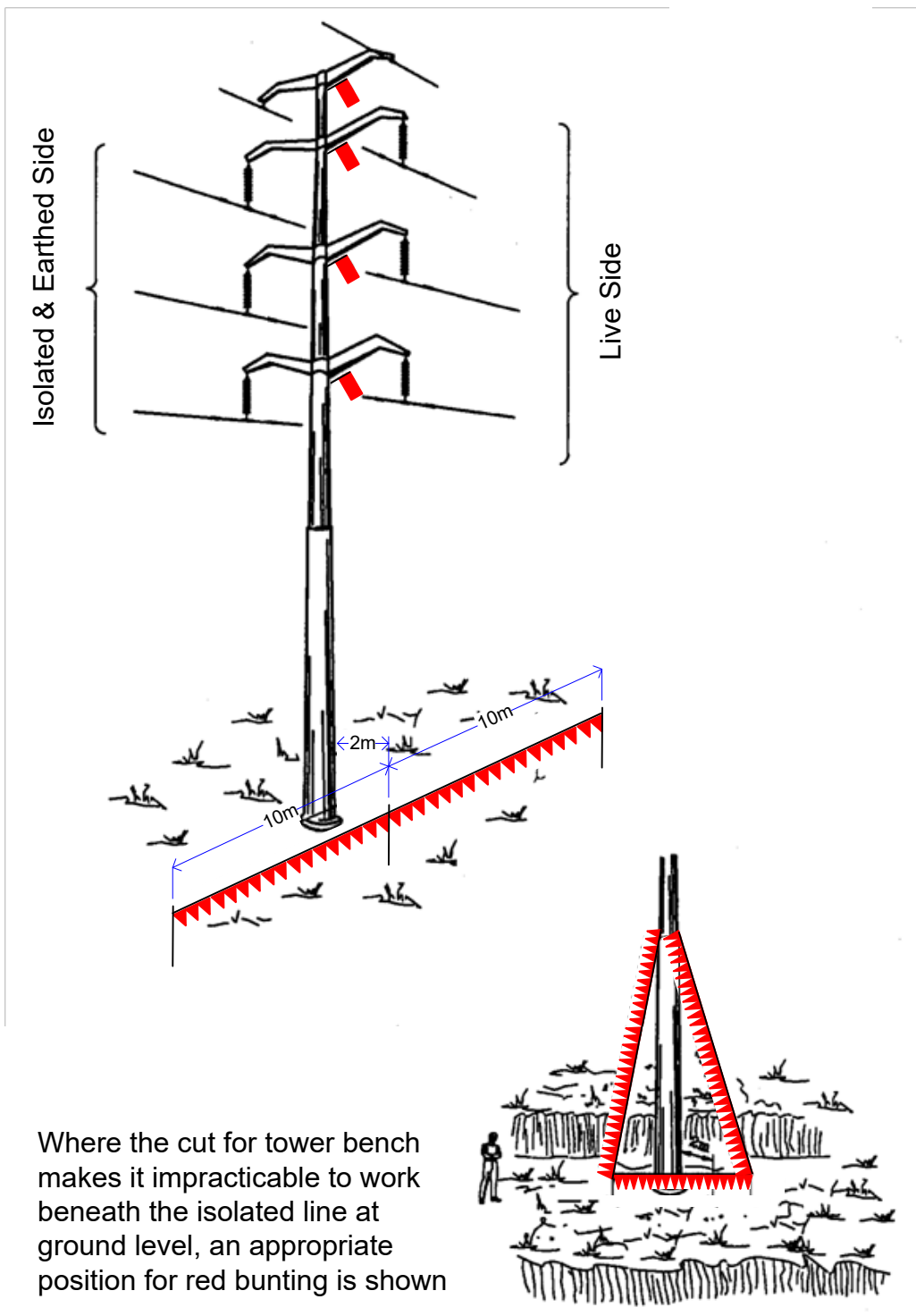

Where the cut for tower bench makes it impracticable to work beneath the isolated line at ground level, an appropriate position for red bunting is shown

Warning: A printed copy of this document may not be the current version. Please refer to the Wire to verify the current version.

5.2 Persons to Keep Clear of Equipment

Workers engaged in work on HV overhead lines shall ensure that all persons:

- (a) Keep clear (at least 3 metres) of structures, plant, and equipment associated with the work.
- (b) Directly engaged in the work are aware of the specific safeguards applying to the work; and
- (c) Keep clear of and do not touch conductor near the ground, unless under insulated working conditions or under bonded work area conditions.

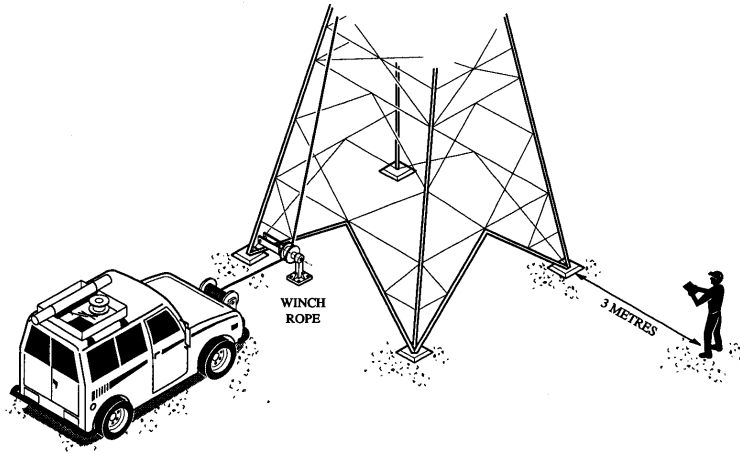

5.3 Earthing Plans

Where work involves the connection, cutting or disconnection of any high voltage conductor, an approved earthing plan is required in accordance with Section 6.4.1 of the Power System Safety Rules.

The earthing plan must describe how over the sequence of work to be completed, the HV electrical apparatus will be effectively earthed. Earthing plans are a critical control for managing the hazards of induced voltages and currents for work on high voltage transmission lines.

Earthing plans must be approved by a person suitably qualified and experienced in the work to be performed. For TransGrid managed works, approval requirements are defined in works program procedures. For works being managed by contractors, the contractor will have to substantiate to the satisfaction of TransGrid's representatives, that the person(s) approving earthing plans are suitably qualified and experienced.

Safe work practices for the cutting or disconnection of any high voltage conductor are contained within Section 5.7 of this document.

Note: When performing work involving the connection, cutting or disconnection of overhead earth wires, not associated with an outage or concurrent work on the HV conductors the hazards from induced voltages and currents and transferred earth potentials need to be assessed and controlled.

For routine tasks in this situation, the earthing, bridging and bonding requirements should be covered in the Safe Work Method Statement for the work.

More complex tasks in this situation must have an approved earthing plan to manage those risks.

5.4 Engineer's Assessment

Situations that may be subject to earth grid voltage rise and or transferred earth potentials require an Engineers Assessment. An assessment can be in the form of a review and endorsement of proposed controls within a work instruction or Safe Work Method Statement.

The assessment shall be undertaken by a suitably experienced Electrical Engineer with degree level qualifications.

Situations requiring an Engineers Assessment include:

1. Stringing conductors and overhead earth wires, Section 5.9, 5.10, including:
 - Spans into substations

Warning: A printed copy of this document may not be the current version. Please refer to the Wire to verify the current version.

- Transmission lines with long parallels with in-service transmission lines
 - Towers carrying an in-service circuit
2. Work involving contact with existing transmission line conductors or overhead earth wires that may be at ground level, Section 5.5.4.
 3. Large work sites, Section 5.8
 4. Testing of HV Overhead Lines, Section 5.11.

The above triggers are not to be considered exhaustive. Should a person planning or performing transmission line work have any concerns regarding a particular work situation with the potential for induced voltages or currents, an “Engineer’s Assessment” should be undertaken.

5.5 Persons Working at Ground Level

5.5.1 Persons Working at Ground Level (Other than on Conductors)

For persons working at ground level, other than on conductors, it is essential that:

- (a) Safety boots are worn;
- (b) In wet conditions ‘Wellington’ type safety boots are worn; and
- (c) Prior to application of Access Authority earths:
 - Ensure batten on pole earth wire is in place; and
 - Locate the standard portable earthing stake no closer than 1.5m to the pole and place a non-conductive cover (eg non-metallic bucket) over any projecting earth stakes as illustrated right.
- (d) After application of access authority earths:
 - Avoid unnecessary approach to structure earth system and to the base of the structure (to avoid high step and touch voltages);

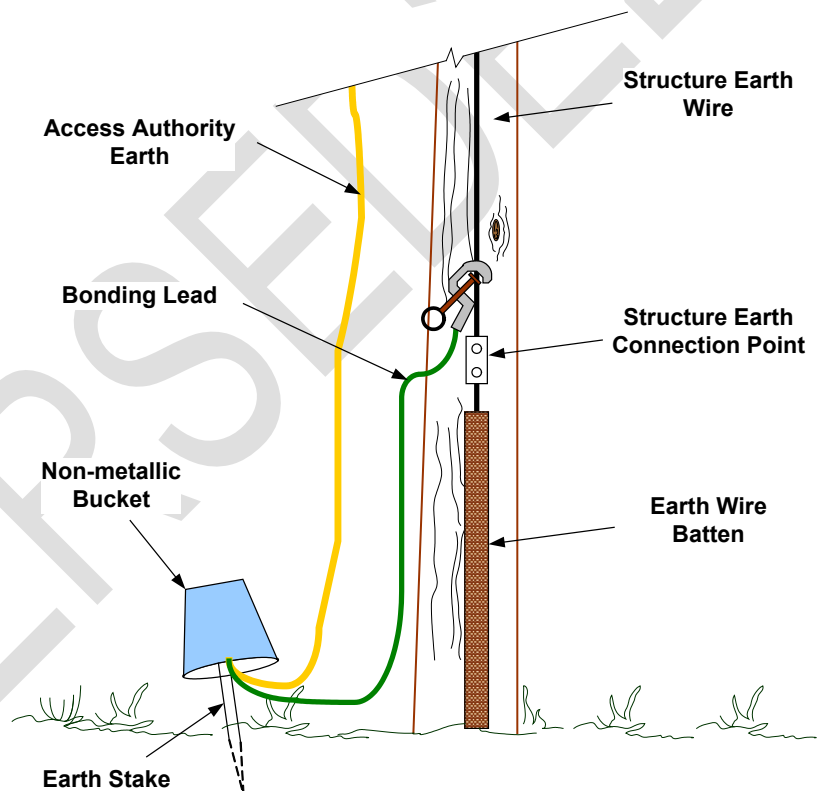

Use an approved insulating ladder for access to both poles and towers. Refer [Attachment B](#)

5.5.2 Persons Working on Conductors or Overhead Earthwires at Ground Level

Bonded work areas at ground level may be used as an alternative to insulated working where higher levels of safeguards are required than could be reasonably obtainable from insulated working.

5.5.3 Safeguards for Persons While Working at Ground Level

To protect persons from hazards whilst working at ground level in bonded work areas, the following safeguards shall be adopted:

5.5.3.1 Provision of Insulated Access to Bonded Work Spaces at Ground Level

This can be achieved by:

- a) Wearing insulating boots while working; or
- b) Providing taped barriers around the work area with special insulated access ways.

Warning: A printed copy of this document may not be the current version. Please refer to the Wire to verify the current version.

5.5.3.2 Provision of Bonding and Access Authority Earths to form an Equipotential Work Area

Bonding and the application of Access Authority Earths ensure that a bonded work area at ground level is a true equipotential area. The following arrangements illustrate these principles:

(a) Substation type earth mats (mat arrangement for making a conductor joint at ground level).

The mat arrangement shown below is for making a conductor joint at ground level. This provides a separate earth mat for each operator, assistant and for the compressor head.

The following safeguards are required in this example:

- i. All persons working in the area must wear insulating boots.
- ii. Bonding leads are used to connect the various parts of the bonded work area.
- iii. Standard portable earthing leads are used to provide the Access Authority Earths which connect the conductor/s to a standard portable earthing stake.
- iv. Where the bonded work area is within 30 metres of a structure earth system, the main earth stake of the bonded work area shall be connected to the structure earth system by a standard portable earthing lead.

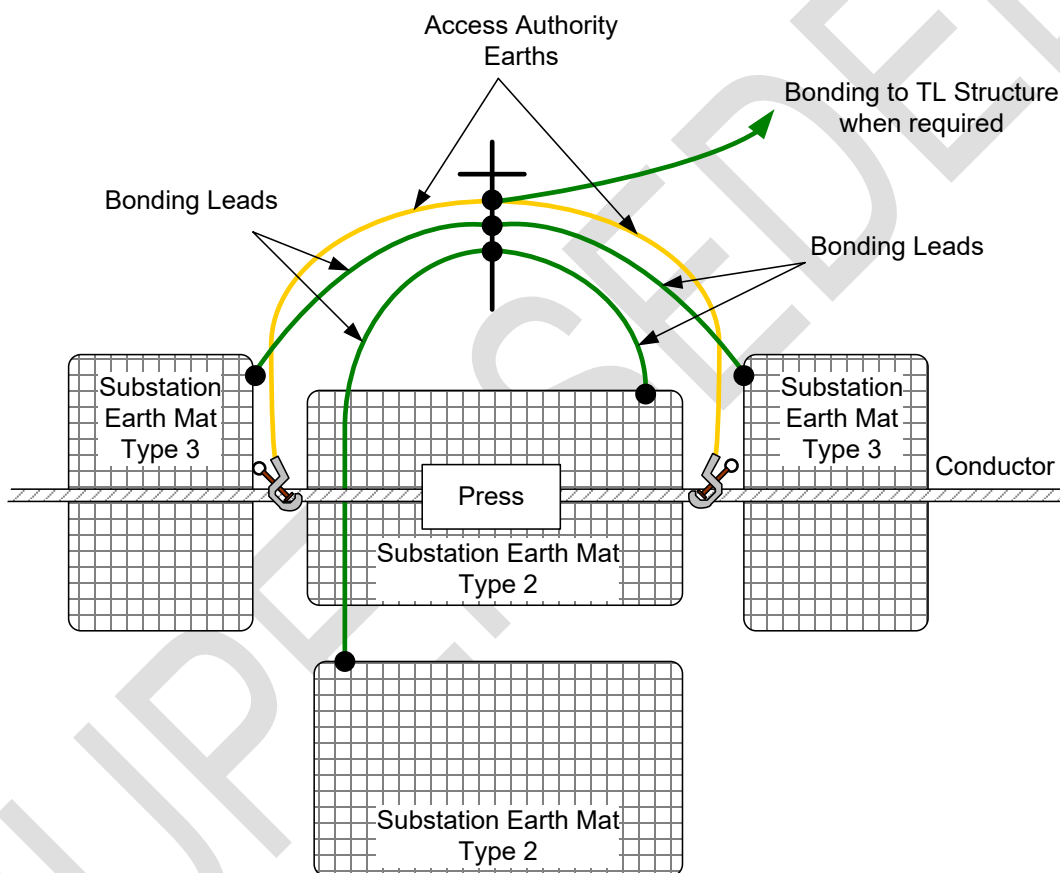

(b) Reinforcing Mesh Mat

Steel reinforcing mesh can be used to form a bonded work area for making conductor joint at ground level as shown below.

The following safeguards shall be used to form the bonded work area:

- i. Taped barriers with special insulated access ways;
- ii. Bonding leads are used to connect the various conducting components of the bonded work area;
- iii. Standard portable earthing leads are used to provide the Access Authority Earths which connect the conductor/s to the earth stake;
- iv. Where the bonded work area is within 30 metres of a structure earth system, the main earth stake of the bonded work area shall be connected to the structure earth system by a standard portable earthing lead.

Warning: A printed copy of this document may not be the current version. Please refer to the Wire to verify the current version.

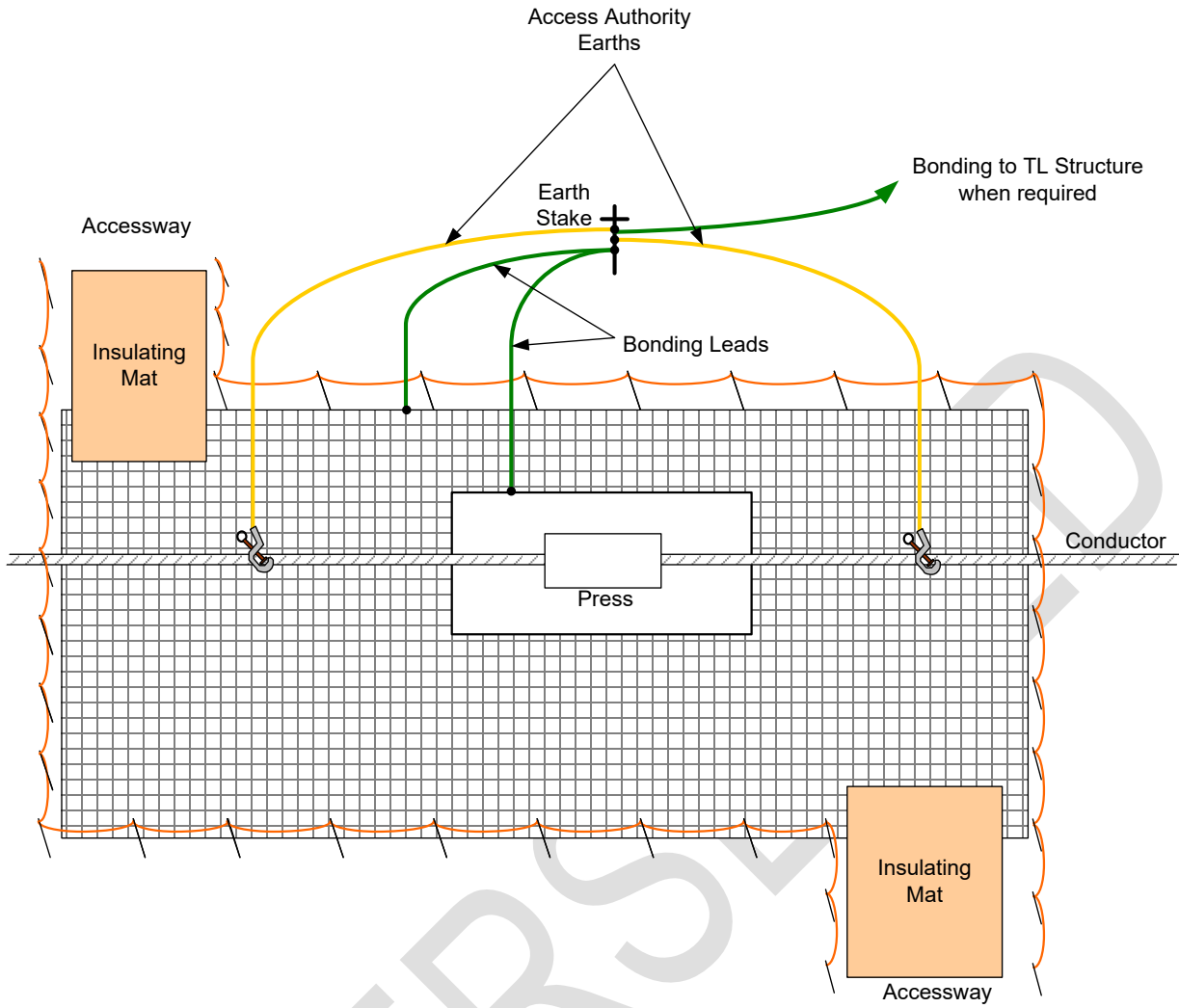

Warning: A printed copy of this document may not be the current version. Please refer to the Wire to verify the current version.

5.5.4 Handling Conductors or Earthwires at Ground Level (Insulated Work Methods)

Insulated work methods ([Attachment A- Insulating Boots, Gloves and Sheet](#)) are required for work involving the handling of overhead line conductor at ground level including:

- (a) Recovering the End of a Broken Line Conductor, Moving and/or Securing Conductor
The method used for handling a conductor under these circumstances is shown in below.

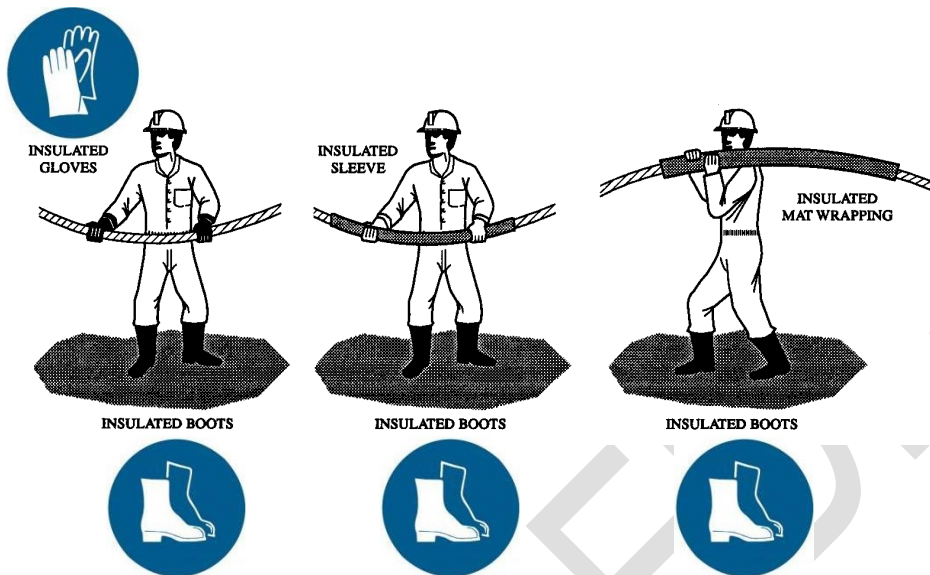

- (b) Making a Joint

Joining of HV conductors on overhead lines is normally performed using compression joints, although preformed splices are sometimes used on some conductor types or for repairing damage to conductors:

- i. Application of a Preformed Splice

A bridging lead is generally not required when the line conductor remains intact, but would be required if the current carrying component of the conductor (i.e. aluminium strands) is significantly reduced. This would be the case if the preformed splice was being fitted as a repair splice. The application of a preformed splice is shown below.

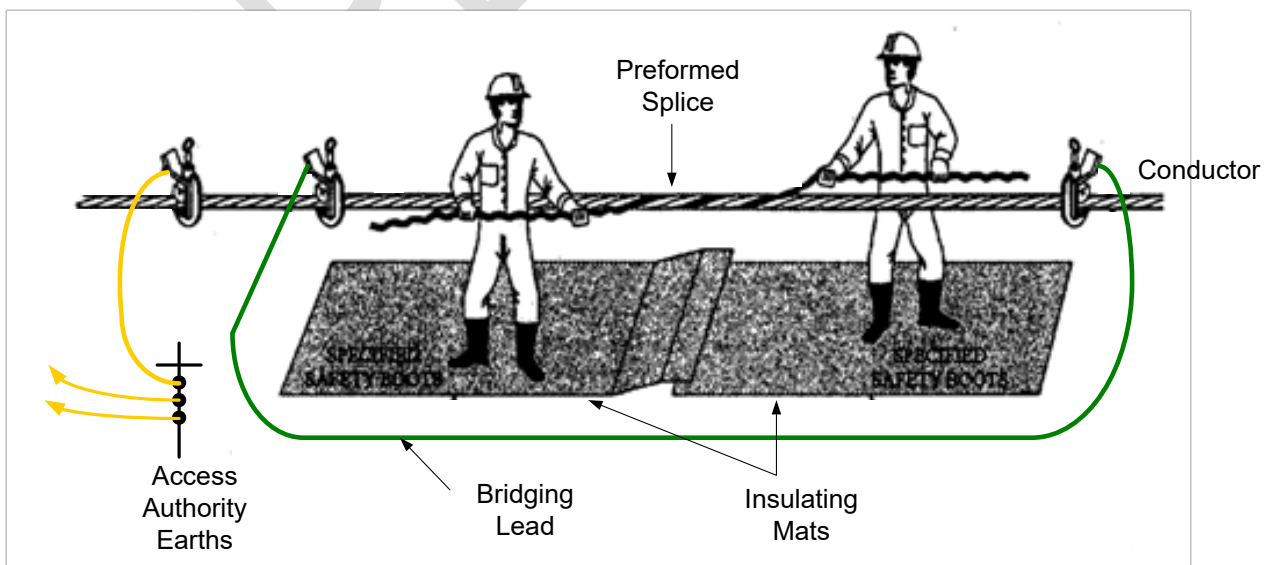

- ii. Application of a Compression Joint

Insulating mats are provided for each person working on the joint and for the compressor head, as shown below.

Warning: A printed copy of this document may not be the current version. Please refer to the Wire to verify the current version.

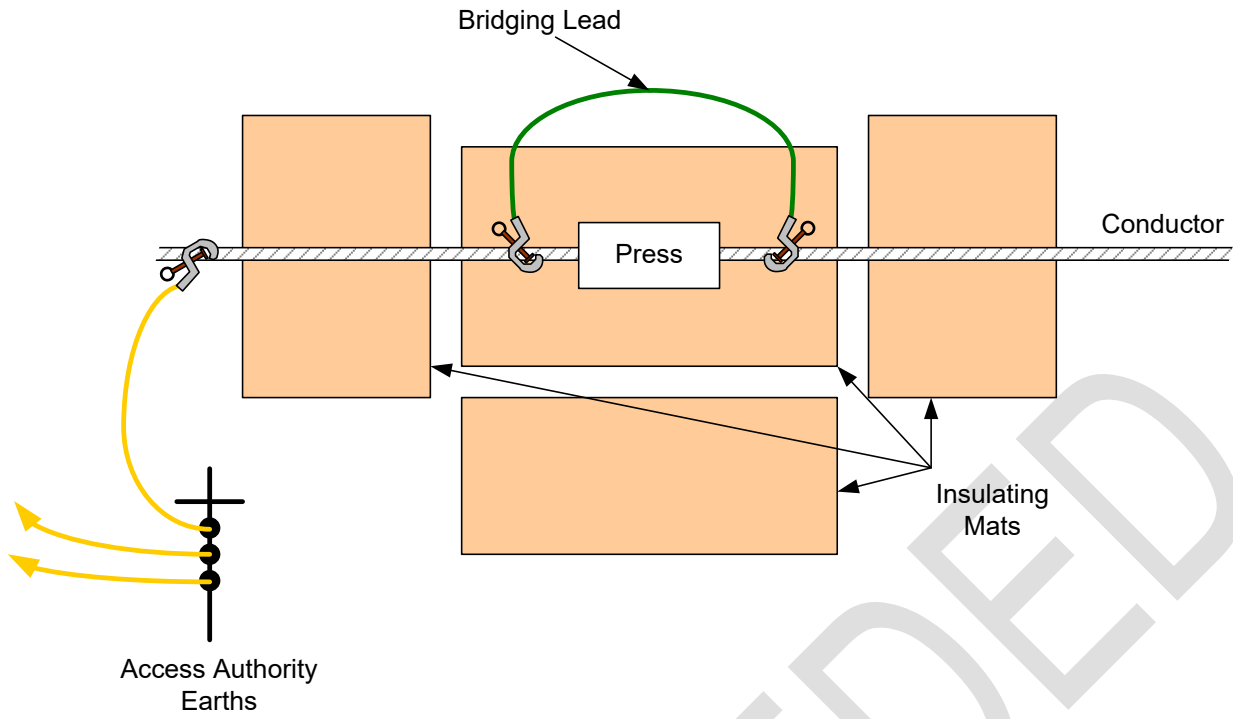

SUPERSEDED

Warning: A printed copy of this document may not be the current version. Please refer to the Wire to verify the current version.

5.6 Persons Working Aloft

For persons working aloft it is essential that:

- (a) Access Authority Earths are to be applied as close as practicable to the point of work, in accordance with the Power System Safety Rules;
- (b) A bonded work space is used for all work; and
- (c) All conducting lines and winch ropes are electrically connected to the bonded spaces.

5.6.1 Bonded Work Spaces Aloft

The bonded work space is the most effective safeguard against electrical hazards for staff working aloft on HV overhead lines.

The bonded work space aloft is created by:

- (a) Application of Access Authority Earths at the point of work;
- (b) Bonding, using bridging leads, of other conducting parts or systems that are **not** directly joined within the Bonded Work Space by the access authority earths.

5.6.2 Bonded Work Space –Steel Tower

Most overhead line steel tower structures are completely bonded around the top of the structure in the "space" of the HV conductors and overhead earthwire when Access Authority Earths are applied as shown below.

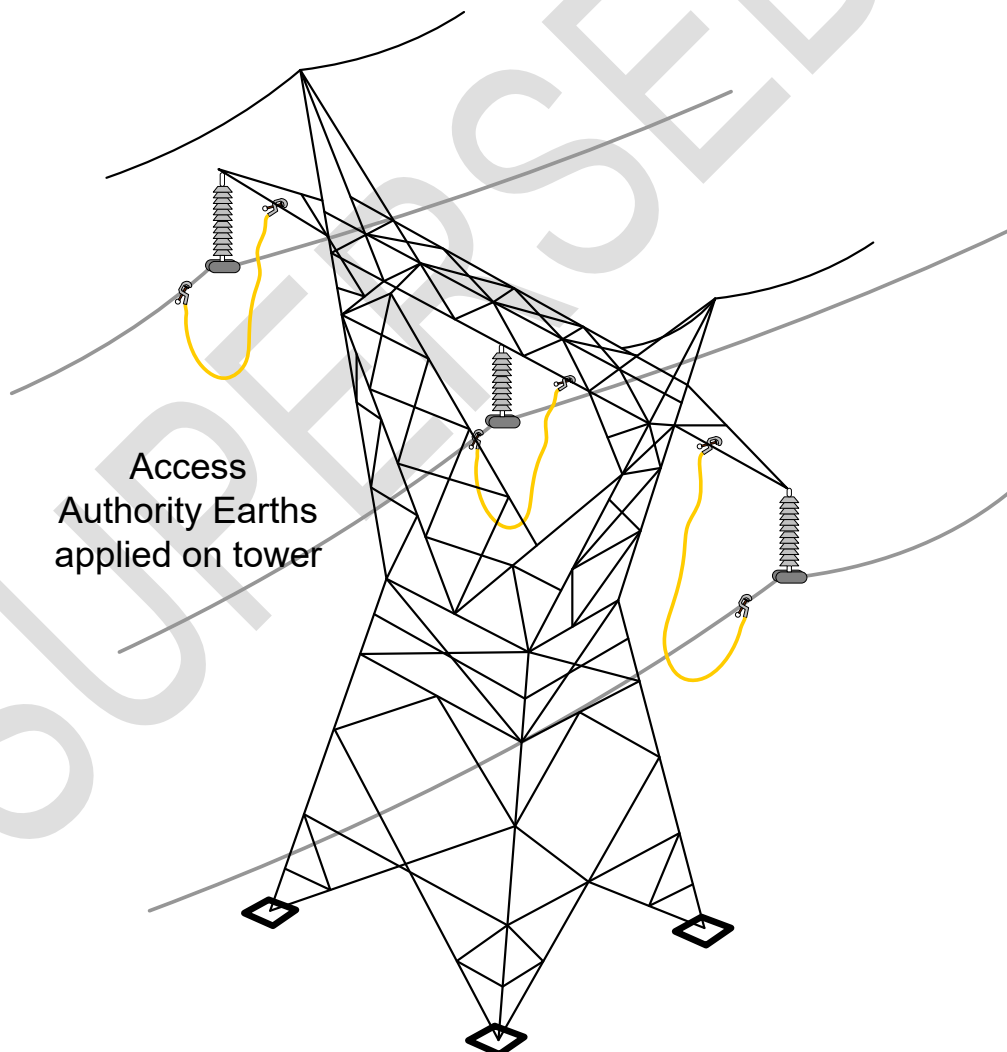

Warning: A printed copy of this document may not be the current version. Please refer to the Wire to verify the current version.

5.6.3 Bonded Work Space – Wood Pole Structure

Most overhead line wood pole structures are completely bonded within the earthing system in the "space" formed by the line conductors and overhead earthwire. The overhead earthwire is connected to the structure earthwire. Access Authority Earths are usually connected to the earthing system at the base of the structure as shown below.

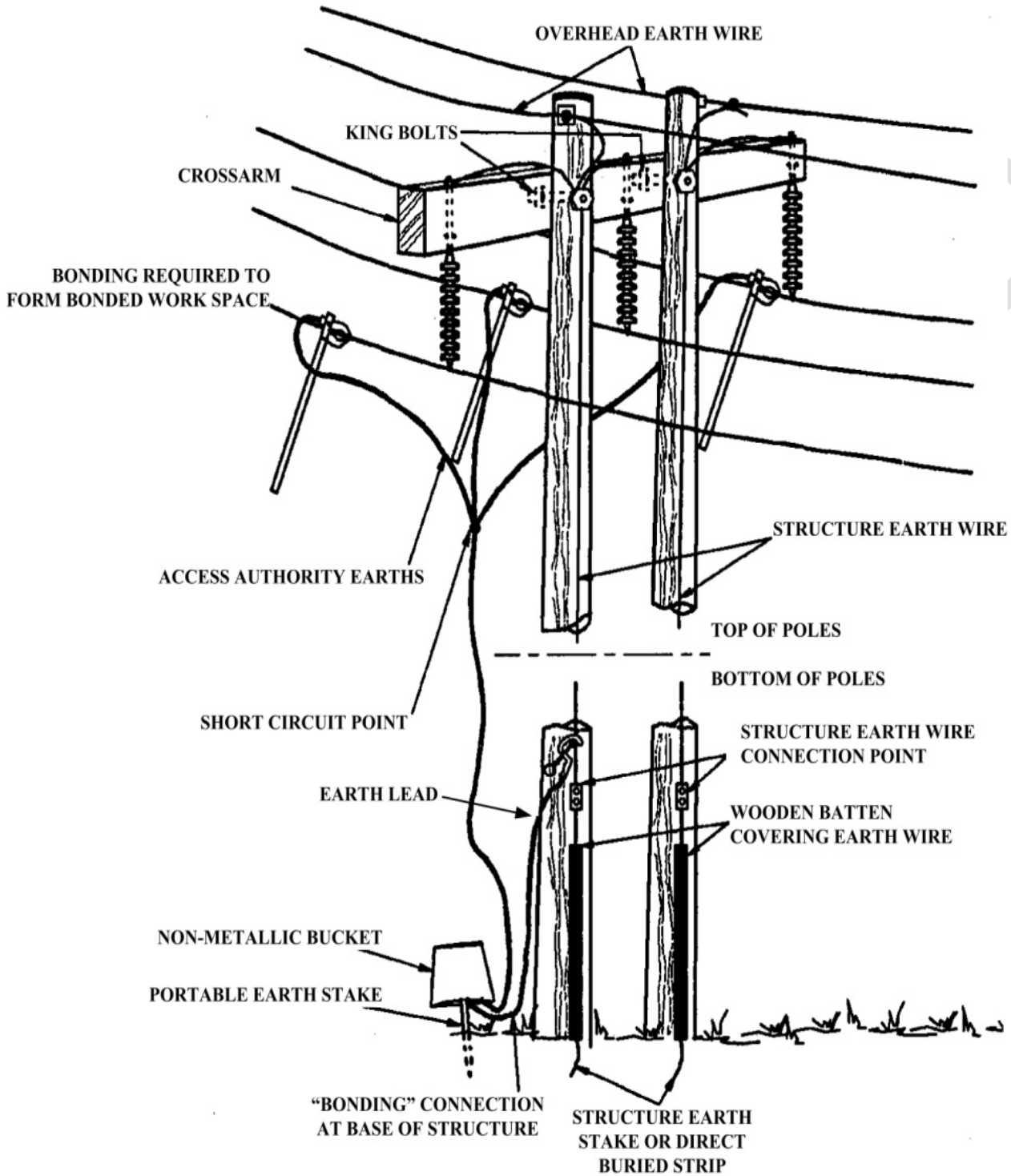

5.6.4 Bonded Work Space – Elevated Work Platform

When using Elevated Work Platforms (EWP) for maintenance work on transmission line structures and conductors, a bonded work space must be established.

The figure below illustrates an (EWP) being used for work on conductor spacers.

Warning: A printed copy of this document may not be the current version. Please refer to the Wire to verify the current version.

The figure shows a conductive platform, which is bonded to the conductor through the bonding lead attached to the boom or platform.

With non-conductive platforms, a conductive mat should be placed in the floor of the platform and bonded to the conductor using a bonding lead. In situations of high induced voltages, boots with conductive soles (or conductive leg-straps passing under the soles of the boots), will improve the effectiveness of the bonding.

Persons remaining at ground level and in the vicinity of the EWP vehicle must keep clear of the earth stake and the vehicle unless required to access the vehicle.

If required to access the vehicle precautions shall be taken to avoid high step and touch voltages as described in Section 5.5 Safeguards for Persons While Working at Ground Level.

The earth stake associated with the EWP shall be bonded to the tower (or pole earth) with a standard portable earthing lead in all cases except where:

- a) The elevated work platform vehicle and earth stake are more than 30 metres from the nearest tower (or pole); and
- b) The EWP platform is not being used for work on the tower (or pole) or associated conductors.

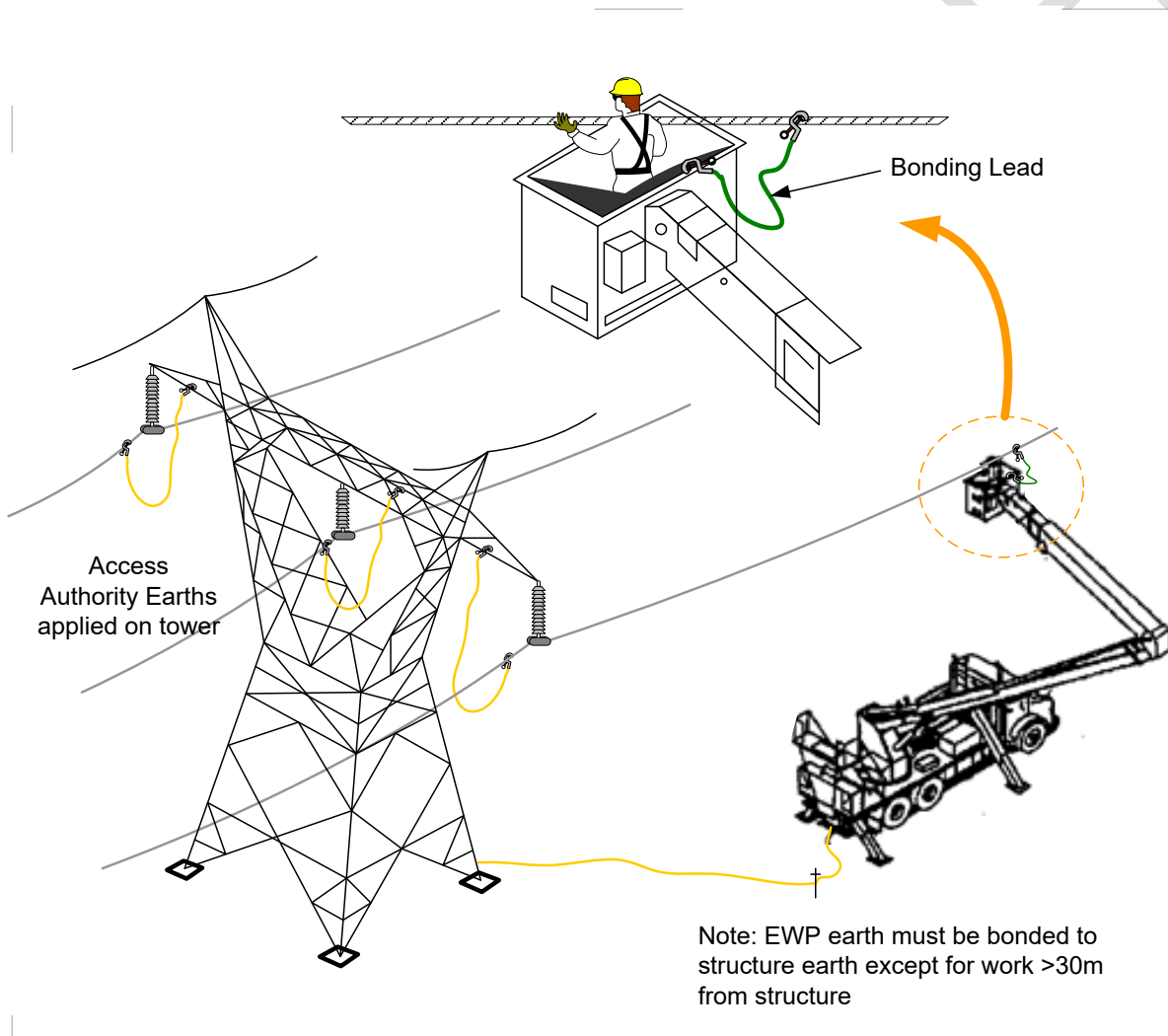

5.6.5 Insulated Working from an Insulated Elevating Work Platform

The figure below illustrates the making of a conductor joint from an elevating work platform which has an insulated arm. Insulated hydraulic hoses must be used from the motorised compressor at ground level to the die head in the bucket.

This work method can be used for a variety of jobs including close examination of conductors, replacement of spreaders, rearranging vibration dampers, etc. The work must be carried out under Access Authority conditions.

Warning: A printed copy of this document may not be the current version. Please refer to the Wire to verify the current version.

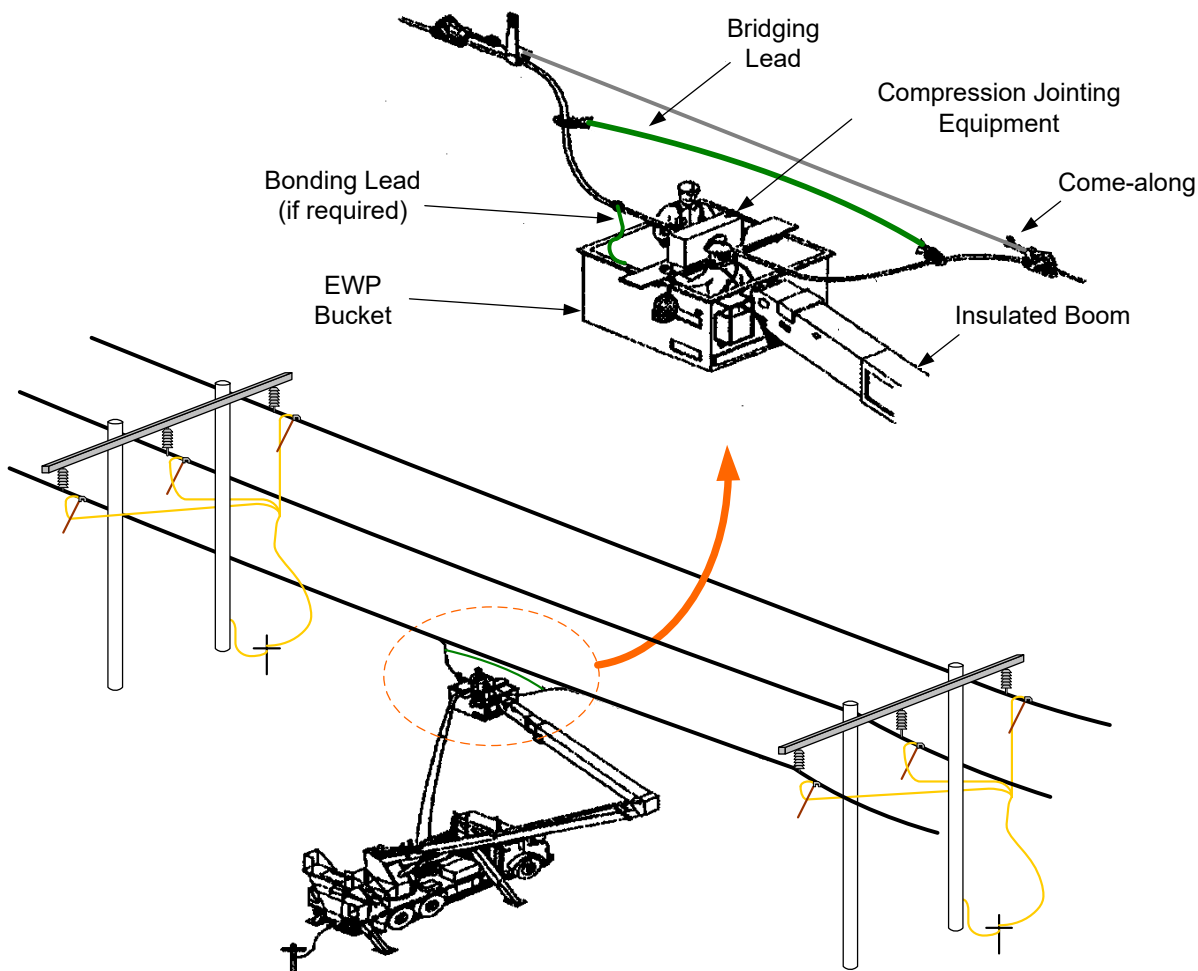

5.7 Making or Breaking Connections on High Voltage Overhead Lines

Persons making or breaking conductors, connections, jumpers, or earthing connections must apply a bridging lead before making or breaking connections.

5.7.1 Application of a Bridging Lead

A Bridging Lead is a conductor which is used to maintain a current path when a conductor is to be broken or disconnected. The lead shall have a current rating which is at least equal to the fault rating of the Access Authority earths used. Details of the lead, clamps and its application are contained in Portable Earthing of High Voltage Conductors.

Two single phase earth leads may be used in lieu of the bridging lead, provided the two earthing leads are connected at the same earthing point. If a connection in a line conductor or structure earthwire is to be broken and the bridging lead removed, then:

- The line conductor or structure earthwire is to be earthed prior to removing the bridge; and
- In the case where a structure earthwire is opened at the base of a structure a bridging lead around the break shall be used throughout the work, the end connected to the earth grid shall be insulated or covered by insulating material before the structure earth is handled.

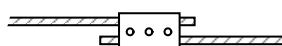

1. Clamp to be removed

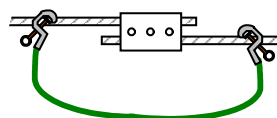

2. Bridge in place

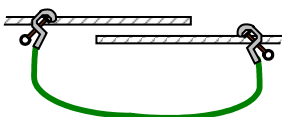

3. Clamp removed

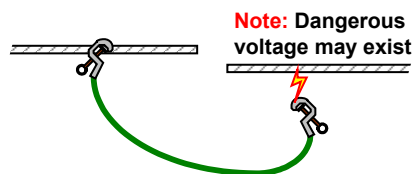

4. Bridge removed

Warning: A printed copy of this document may not be the current version. Please refer to the Wire to verify the current version.

5.8 Large Work Sites

Large work sites are those where the particular work process is to be carried out over multiple spans of a HV overhead line, such as where several towers have collapsed or on line construction or rebuild projects.

At large work sites, where work is to be carried out at ground level on conductors or overhead earthwires, hazards may be present due to the existence of connections between the conductors or earthwires being worked on and remote substation earth mats. These hazards may be transferred to various points over the work site whenever sections of conductor or overhead earthwire are removed or replaced. The removal or replacement of conductors may also introduce hazards of induction from nearby live lines. Therefore working methods on large work sites are to be subject to an Engineer's Assessment.

The electrical hazards to persons can be reduced considerably by breaking connections (jumpers) in **both** the line conductors **and** the overhead earthwires **on each side** of the large work site. In addition, it may also be necessary to insert an insulator in the earthwire attachments at the point of breaking connections (jumpers).

5.9 Stringing an Overhead Line Parallel to an In-Service Line

Persons working on the stringing of conductors or overhead earthwires on HV overhead lines which run parallel to an in-service HV line can be subject to significant hazards from induced voltages and currents.

5.9.1 Work Areas and Equipment

The stringing process may involve some of the following items of equipment:

- a) Draw ropes (non-conducting draw wires);
- b) conductors/earthwires;
- c) drums - for winding on conductors, earthwires, or draw wires;
- d) drum stands - which may be fitted with braking or rewinding mechanisms;
- e) winch - for pulling out conductor/earth wire/draw wires;
- f) tensioning machines - for tensioning conductor/earth wire during run-out; and
- g) jointing presses - for joining conductor/earth wire.

The equipment allocated for the work may be grouped at various locations, the purpose of which can vary with the work method used.

A commonly used arrangement involves a main work-site and a subsidiary work-site. These are described in detail in the following sections:

5.9.1.1 Main Work Site

A main work site could be as large as 100 metres x 30 metres, and include the following equipment:

- a) draw rope/wire drums - mounted on stands;
- b) conductor drum mounted on stands, with braking;
- c) earth wire drums - mounted on stands, with braking;
- d) conductor tensioning machines;
- e) conductor jointing machines - trailer or truck mounted;
- f) sufficient space adjacent to the work site for storage of conductor drums and overhead earth wire drums;
- g) sufficient space adjacent to the work site for vehicles/cranes etc. which are not directly involved in the work while the running-out of conductor or earth wire is in progress.

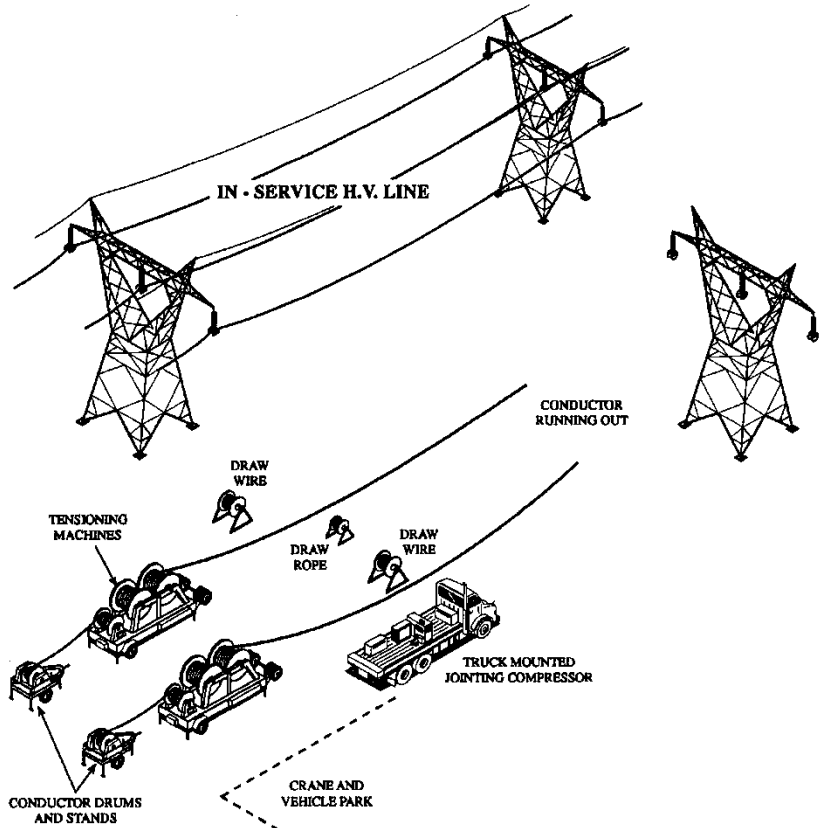

The diagram, at right, shows an example of a main work site.

5.9.1.2 Subsidiary Work Site(s)

A subsidiary work site is established over a small area for intermediate jointing, winching or other work associated with the draw wire or conductor.

The diagram at right shows an example of a subsidiary work site.

5.9.2 Standard Safeguards to be applied for Stringing Operations

Effective earthing of draw wires, earth wires and conductors is to be maintained throughout the duration of the run out. Earthing is to be as follows.

- (a) **Running out operation where a winching method is used:** Two earths are to be applied, one close to the drum site, the other close to the winch site.
- (b) **Running out operation from a drum carried on a moving vehicle:** A single earth is to be applied close to the commencement point of the section.

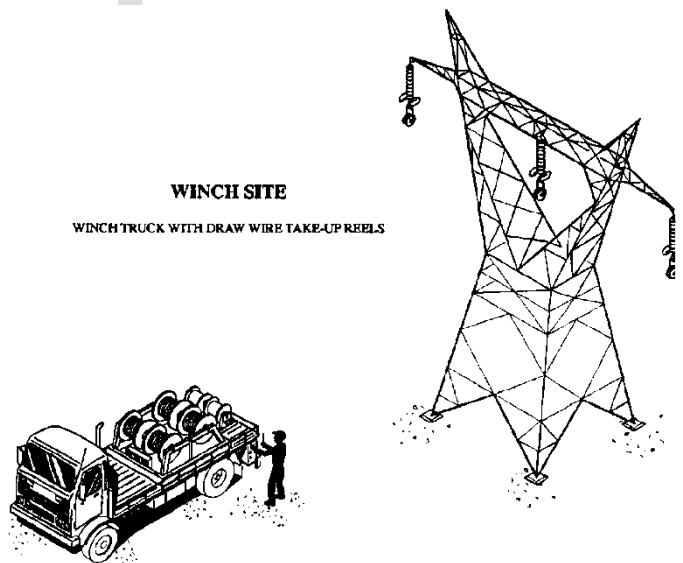

This earthing should be carried out using specially designed fittings such as rolling earths (See Appendix C). When bundled conductor is being run out, each single conductor making up the bundle is to be individually earthed.

After being run out, each phase conductor and earth wire is to be earthed, using a standard portable earthing lead, at intervals of not more than 3 km by connecting the earths to either the structure steelwork or the structure earthing system.

In cases where overhead earth wires have been permanently bonded to the structure or the structure earthing system at an earthing location, earths will only be required on the phase conductors.

The location of all such earthing connections must be recorded so that a check can be made to ensure that they have been removed before the line is energised.

Warning: A printed copy of this document may not be the current version. Please refer to the Wire to verify the current version.

5.9.2.1 Additional Safeguards to be applied for Stringing Operations in Areas of Moderate Induction Exposure

Note: The degree of induction exposure will be determined as part of the Engineers Assessment.

Additional safeguards required are listed below:

- When a crew of line workers is carrying out work at a structure and there is a possibility that the workers, their tools, or other items of equipment may make contact with conductors (Including overhead earthwires), such conductors are to be connected to the structure steelwork or the structure earth system by means of bonding leads, for the duration of the work. The leads must not be broken during the course of the work. Such connections shall be recorded;
- While line work, (i.e. running out of conductors and earth wires, stringing and all subsequent work) is being carried out, mobile equipment such as cranes operating at any structure is to be connected to the structure earthing system by means of a standard portable earthing lead.
- All persons associated with running out, stringing and other line work at ground level, are to work under insulated working conditions and are to be briefed on the hazards associated with the work.
- Draw wires shall be insulated from pulling vehicles.
- Jumpers between affected sections of the line and jumpers linking these sections to the adjoining sections shall not be installed until all other overhead line work has been completed.

5.9.2.2 Further Additional Safeguards which may be required for Stringing Operations by the Engineers Assessment

The further additional safeguards are detailed below:

- Main work sites are to be established as a bonded work area. All material and equipment associated with the running out of draw wires, earth wires and conductors are to be bonded to it via a central stake as shown below.

Entrance to or exit from the bonded work area is to be via insulating mats, with a taped barrier defining the edges of the bonded work area.

- Subsidiary work sites are to be established as bonded work areas.
- No conductor, earth wire or metallic draw wire shall be permitted to come within 2.5 metres of ground level at any location other than at a main or subsidiary work site.

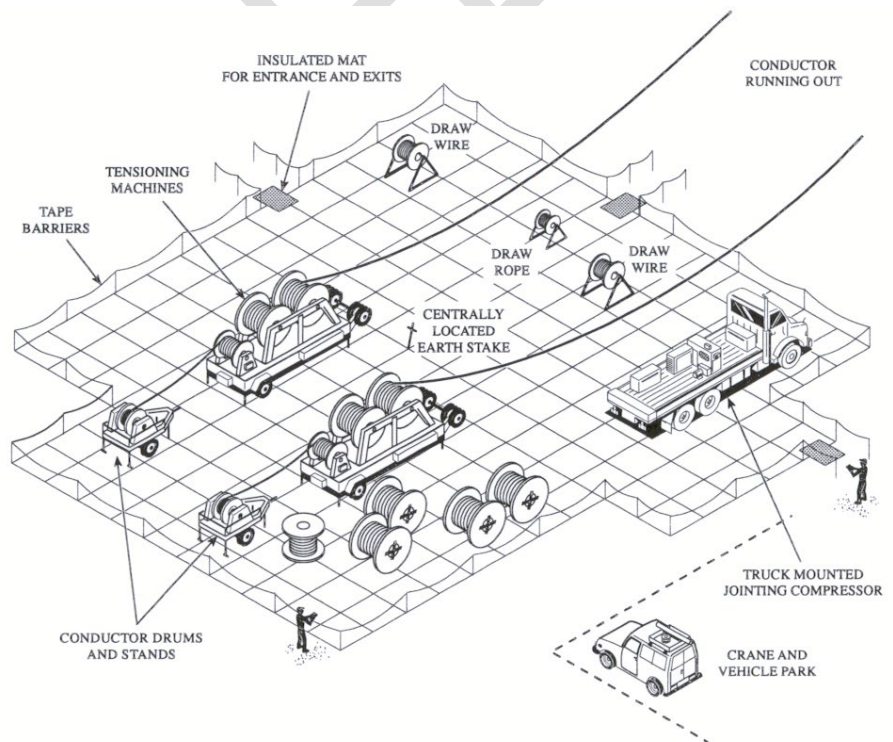

All connections used in the earthing arrangements under (a) and (b) above are to be made using standard portable earthing leads. For details on bonded work areas at ground level refer to Section 5.5

The running out of metallic draw wires or conductors from a drum carried on a moving vehicle is not acceptable under these circumstances.

Warning: A printed copy of this document may not be the current version. Please refer to the Wire to verify the current version.

5.10 Stringing Conductor on Landing Span to HV Substations

Staff working on the stringing of conductors and overhead earthwires up to the landing span in the substation, i.e. between a HV overhead line and a structure in a HV Substation can be subject to significant hazards from the rise in voltage of the substation earth grid under system fault conditions or system switching activities.

Earth grid voltage rise can be transferred to persons outside the switchyard and may occur at any time. Similarly, staff working within the switchyard can become connected to a remote earthing system which can lead to a hazardous voltage during a rise in the voltage of the substation earth grid.

5.10.1 Standard Safeguards

- a) It is best practice for all work on the HV overhead lines to be completed before the landing span is erected. If this cannot be done it may be necessary to temporarily install a single disc insulator in the overhead earth wire at the first structure and to leave the conductor jumpers completely disconnected or tied back onto the landing spans.

These precautions will limit the extent of transfer voltage effects.

- a) The connection and disconnection of jumpers is to be carried out using the standard bridging process.
- b) All terminations to conductor or overhead earth wire made at ground level in the general vicinity of the landing spans are to be carried out under bonded work area conditions.
- c) The person in charge of the work is to ensure that the Controller is advised prior to the commencement and on completion of stringing operations involving landing spans.

5.10.2 Outline of Procedure for Stringing landing Spans

Access Authority procedures must be implemented prior commencement of the work.

Procedures to be followed for stringing landing spans are:

- a) A bonded work area shall be established around the first structure and connected to the structure earth (Figure below). Insulating boots are to be worn by all persons working at ground level during the course of the work. (This will be a safeguard from possible step and touch voltage which could arise when the structure is connected to the switchyard earth grid).
- b) The first structure shall be bonded to the switchyard earth mat in the following way:
 - i. using a standard portable earthing lead, the lead shall be connected to the first structure outside the switchyard;

And then:

- i. using insulated work methods, the lead shall be run out towards and into the switchyard;
 - ii. using insulated work methods, persons shall connect the lead to the switchyard earth grid as shown in the diagram below.
- c) Winches, brakes and other equipment associated with the stringing operation are to be connected to the switchyard earth mat directly or via the earthing of the first structure. The connection shall be carried out using the procedure outlined in (b) above.
- d) Stringing of each conductor or overhead earthwire shall be carried out in such a way that neither the conductor nor the overhead earthwire makes contact with the switchyard earth grid whilst the conductor is being handled by persons outside the switchyard.

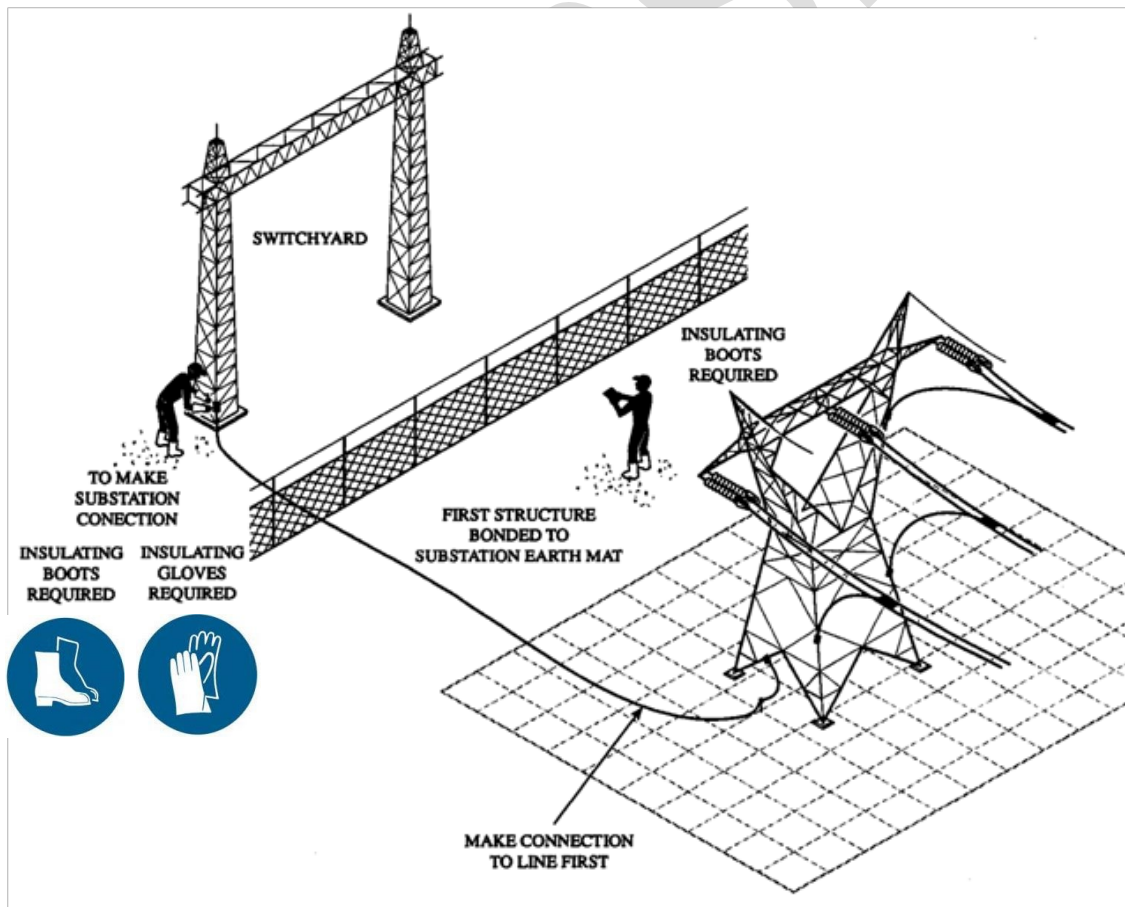
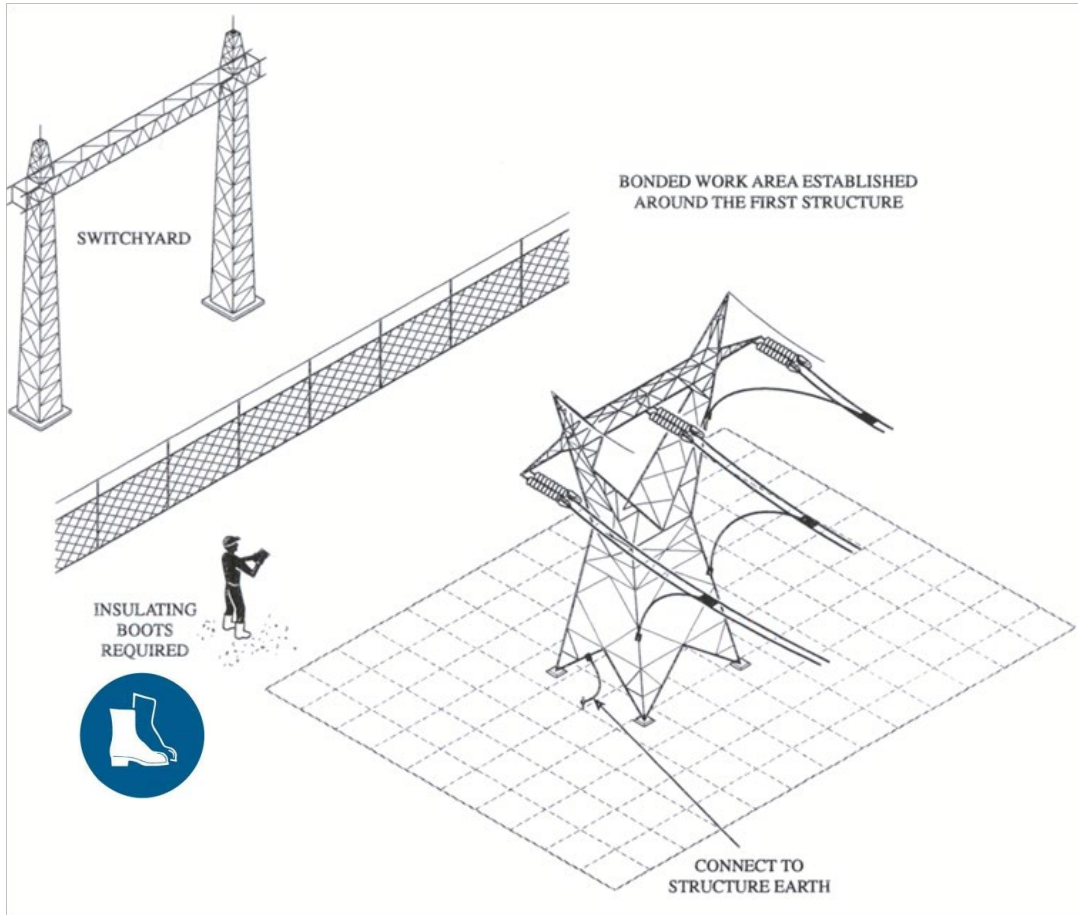

Warning: A printed copy of this document may not be the current version. Please refer to the Wire to verify the current version.

Either of the following options may be used:

Method A

- i. The conductor or earthwire drum shall be set up at least 30 metres outside the substation boundary fence;
- ii. The conductor or earthwire shall be pulled away from the substation using conventional equipment;
- iii. The conductor or earthwire termination shall be attached to the first line structure outside the substation;
- iv. The other end of the conductor shall be pulled into the switchyard manually by persons working under insulated working conditions as shown in the following diagram.

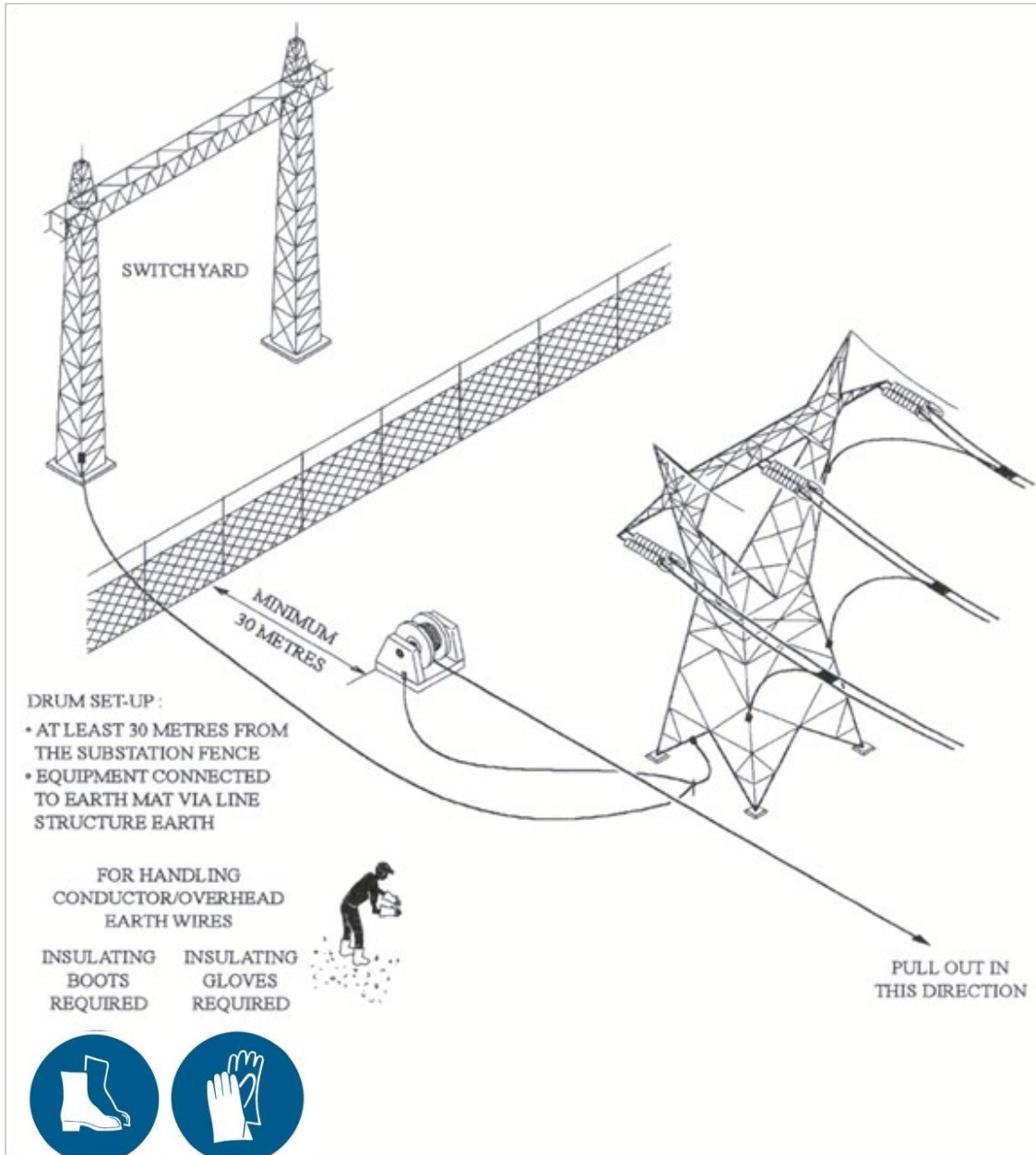

Warning: A printed copy of this document may not be the current version. Please refer to the Wire to verify the current version.

Method B

- i. The conductor or earthwire drum shall be set up remotely;
- ii. The conductor or earthwire shall be pulled towards and into the substation using a suitably sized non-conducting rope (e.g. nylon) within the area extending 30 metres from the boundary fence;
- iii. Persons pulling the conductor or earthwire into the substation shall use insulated working conditions as shown below.

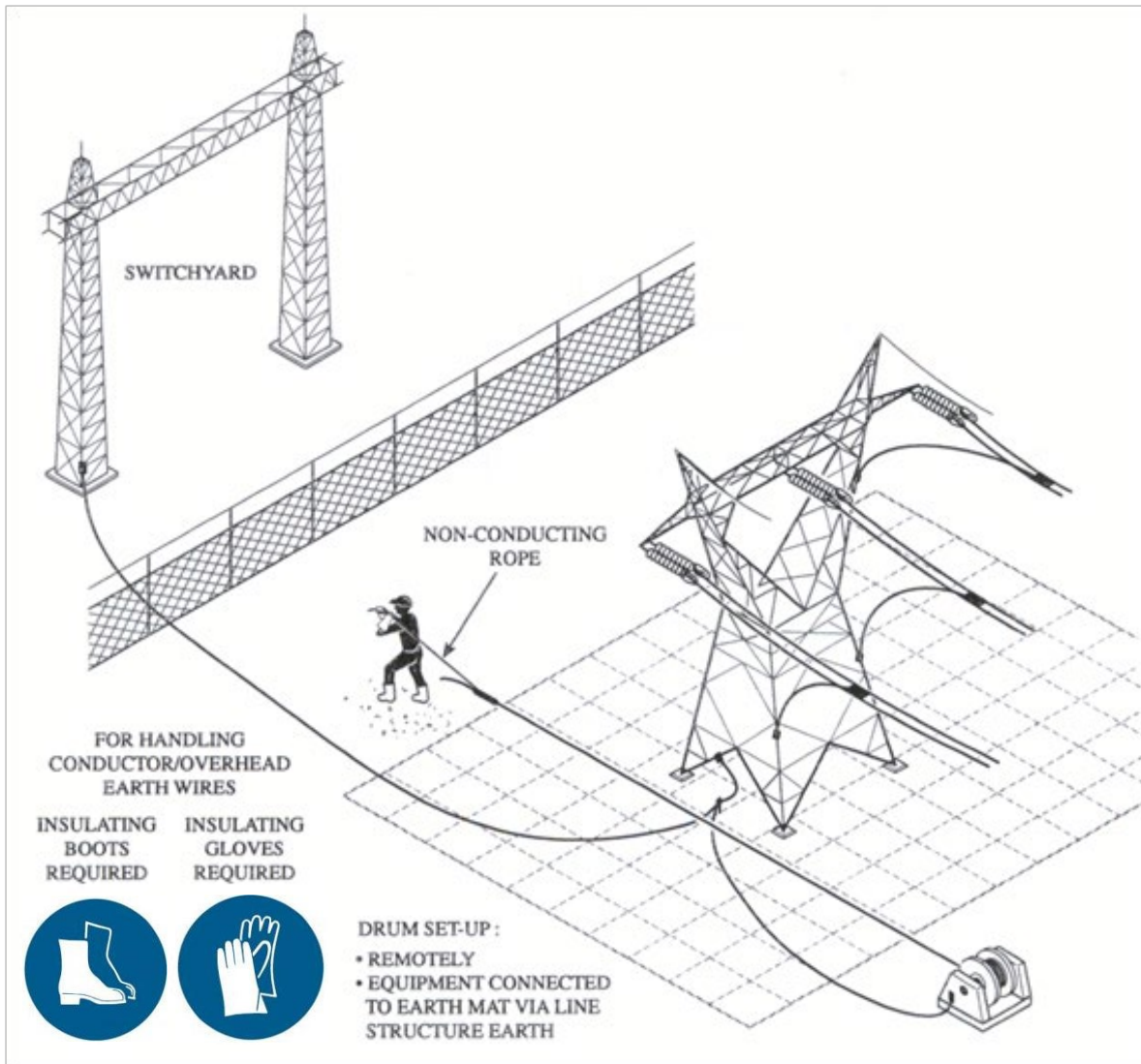

5.10.3 Special Circumstances

Where the profile of the terrain makes it impracticable to bond the first structure of the bonded work area to the switchyard earth-mat using a standard portable earthing lead, a bare overhead earthwire connection may need to be established as an alternative.

This connection can be in the form of:

- a) Existing overhead earthwires (or conductors) including those on adjacent lines or
- b) A pilot wire pulled towards the substation in accordance with the method in B above.

5.11 Testing of HV Overhead Lines - Safeguards for Use of Test Instruments

Persons using test instruments on high voltage overhead lines may be subjected to high level electrical hazards during the period in which it is necessary to remove safety earths to obtain effective measurements.

The principal hazards are:

- induced voltages: where the line under test is closely coupled with other in-service HV lines, resulting in high levels of induced voltages;

Warning: A printed copy of this document may not be the current version. Please refer to the Wire to verify the current version.

- earth mat voltage rise: from system faults or switching surges, which could appear at the testing site through the overhead line conductors or overhead earth wire;
- lightning surges: direct strike or induced, could be directly conducted into the test instruments; and
- voltage gradients in the vicinity of the test site could be significant if the line becomes alive while the safety earths are removed.

The following procedures will provide safeguards for persons conducting tests on HV overhead lines which are subject to routine induction and transfer effects.

Such tests could involve the use of the following devices:

- Meggers;
- Battery with ammeters.

Proposals to carry-out complicated tests or tests in potentially hazardous circumstances, should be discussed with the person responsible for the tests.

To safeguard persons during the tests the following procedures shall be applied in addition to the requirements of the Power System Safety Rules:

- a) An Engineer's Assessment shall be made of the electrical hazards which may be encountered and the working methods to be applied.
- b) Where the line to be tested is:
 - On a double circuit structure and the other circuit is 'alive', or
 - Closely paralleled with another in-service line

The proposed working methods must be discussed with a representative of the testing contractor to check the adequacy of the proposed working methods.

- c) All testing work shall be under insulated working conditions, involving the use of:
 - An insulating mat;
 - Insulating boots (to safeguard persons while not on mat)
- d) Electrical supplies for the instruments being used in the tests are to be confined to the Insulated Work Area.

For example, power for testing equipment should come from a battery and inverter -both standing on the insulating mat. Where it is not possible to carry out tests without external 240V supply an isolating transformer insulated to withstand 15 kV between windings shall be used.

- e) A spark gap (or suitable alternative protective device) capable of handling the electrical hazards which may arise shall be provided across the input to the instrument, between the line conductors under test and the earth.
- f) Test leads shall not be connected to or disconnected from overhead line conductors unless Access Authority earths are in place at the work site.
- g) The conductor under test shall be unearthed for the minimum time necessary to carry out the test.
- h) Test leads shall be located at the side of the instrument remote from the person taking the reading.
- i) Persons are to be warned immediately prior to removal of Access Authority earth(s) and shall be directed to keep clear of the test leads while they are connected to the unearthed conductor.
- j) Persons carrying out testing must make contact with only one part of the test instrument at a time during the currency of the reading process.

The following figure illustrates a typical layout for the requirements to test HV overhead lines.

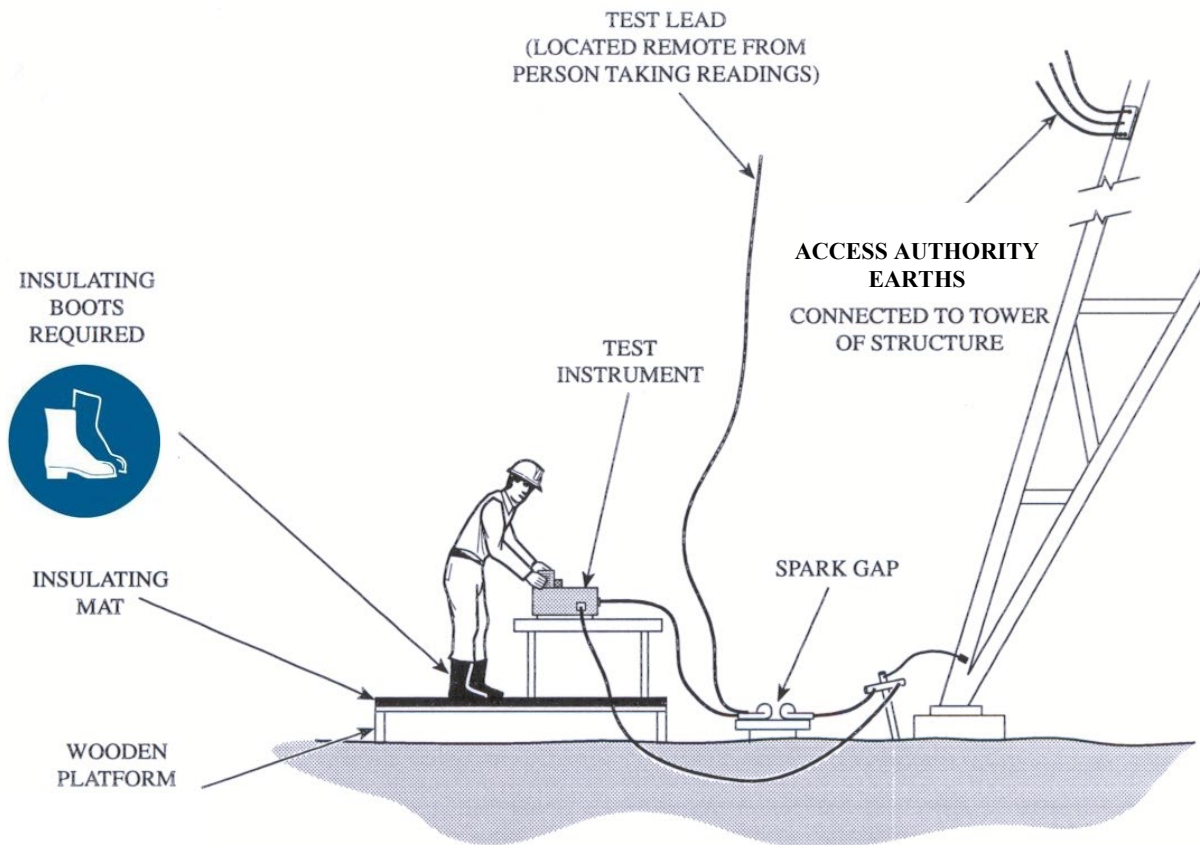

5.12 Work on Structure Earthing Systems

A HV Transmission Line Structure Earth System is the buried earthing system associated with a transmission line pole or tower.

Such a system can vary from fixed local earth stakes to an earth strip buried beside the butt of the pole(s), to a buried strip or deep earth stakes connected to a steel tower. The system reduces the likelihood of lightning causing transmission line insulator flashovers and provides some reduction in voltage gradients adjacent to the structure legs. It also provides a path for return current in the event of a fault on the transmission line.

Work on structure earthing systems shall be in accordance with the requirements of sections 6.1.4 and 6.3.6 of the PSSR and the requirements of the document Safe Work Practices for Bridging of Structure Earthing.

6. Accountability

Title	Responsibilities and Accountabilities
Head of HSE	Maintenance and ownership of this work instruction
Manager/ Training	Implementation of this work instruction
Authorised persons	Comply with this work instruction

7. Implementation

This work instruction is to be implemented in conjunction with the implementation of TransGrid's Power System Safety Rules. It will be available as a resource, published on the Wire.

Warning: A printed copy of this document may not be the current version. Please refer to the Wire to verify the current version.

8. Monitoring and Review

The Power System Safety Rules Manager is responsible for the ongoing monitoring and review of the documents associated with the Power System Safety Rules. This can include but is not limited to:

- (a) Requesting regular feedback on the effectiveness of procedures and work instructions. Appropriate feedback tools include focus groups and WHS consultative committees.
- (b) Where a change has occurred in our processes; and
- (c) Recommendations arising from incidents.

9. Change from previous version

Revision no	Approved by	Amendment
3	Krista-Lee Fogarty, Head of HSE	<ul style="list-style-type: none">> Document updated to new template.> Diagram in 5.1.2 updated to show the flagging applied closer to the centre of the tower> Section 5.3 on earthing plans updated with more detail.> References to Engineers assessment to determine induction hazard level in 5.9.2.1 & 5.9.2.2.> Section on Work on Structure Earthing systems added.> Appendix C detailing rolling earths added.
2	Ken McCall, Manager/Health, Safety and Environment	<ul style="list-style-type: none">> Section 4.1.1 Include reference to PSSR 6.4.1 (d), use of coloured flags.> Section 4.4 Added in Engineer's Assessment section and update references in rest of document.> Section 4.11 reference to F.L.O.S removed. This test equipment is obsolete.> Document links revised.
1	Ken McCall, Manager/Health, Safety and Environment	<ul style="list-style-type: none">• Section 4.4.4 wording revised. Refer INS 1550• Section 4.6 wording revised• Document links revised.

10. References

Power System Safety Rules
Proving High Voltage Conductors De-energised
Portable earthing of High Voltage Conductors
Access for work on High Voltage Overhead Lines

11. Attachments

Appendix A – Insulating Boots, Gloves and Sheet
Appendix B - Using an Approved Insulating Ladder for Access
Appendix C – Rolling earths

Warning: A printed copy of this document may not be the current version. Please refer to the Wire to verify the current version.

Appendix A - Insulating Boots, Gloves and Sheet

A.1 Safety Boots for Line worker

For work on overhead lines at ground level special safety boots are provided to safeguard line workers from electrical hazards. These boots have the following characteristics:

- a) Moulded rubber sole;
- b) Leather uppers with “smoothed-out” exterior –suede leather is not acceptable;
- c) Leather tongue sewn to deter ingress of moisture.

For work under wet conditions, ‘Wellington’ type safety boots are provided which have moulded rubber soles and a safety type steel toe cap, refer figure right.

A.2 Insulating Boots

Insulating boots are special boots of the “Wellington” or “Half Wellington” type made from plastic or non-conducting rubber with proven levels of insulation. These boots must have been tested to withstand 15 kV AC for 1 minute within the previous 12 months.

Insulating boots are to be used for working in special situations where an Engineer’s Assessment has determined the work site as a hazardous location. Prior to use, these boots are to be inspected to ensure that they are clean, free from cuts, punctures or metallic pieces lodged in the tread or sides. When not in use insulating boots must be carefully stored and on completion of work, must be cleaned and inspected before returning to storage.



A.3 Conducting Boots for Live Line Work

Conducting boots used for Live Line Work are NOT suitable for overhead line work at ground level.

A.4 Insulating Sheet

Insulating sheets are marketed as neoprene sheet and are also known as neoprene rubber or polychloroprene. Minimum sheet thickness is to be 5mm. Insulating sheet may be used singularly or in multiple units and must:

- a) be laid on ground which is free of surface water;
- b) provide for a minimum overlap of 100 mm where sheets are laid together;
- c) be laid on a wooden platform (or planks) in situations where:
 - the ground surface prevents direct laying; or
 - the sheeting may be damaged during the course of work.

Insulating sheet must be inspected prior to use for general condition and for cuts and punctures and shall have been tested to 15 kV AC within the previous 12 months. Sheeting having significant damage must not be used for insulating purposes. When not in use, sheeting must be carefully cleaned and stored.

A.5 Insulating Material for Covering Conductors

Where a line conductor is lowered, it may be necessary to provide insulation around the conductor to protect persons working at ground level from possible electrical hazards (refer Section 5.5.4). Insulating sheet may be used for this purpose.

As an alternative, a spiral split neoprene or non-conductive rubber hose, tested to withstand 15 kV AC for 1 minute within the previous 12 months, may be used for the insulation of lowered conductors. The use of these insulated work methods must only be carried out under the following conditions:

Warning: A printed copy of this document may not be the current version. Please refer to the Wire to verify the current version.

- Where a commissioned line is isolated and earthed and Field Access Authority Earths are applied under Access Authority conditions; or
- Where a line being constructed, is isolated and earthed according to the specified requirements of the construction.

A.6 Gloves for Insulated Working

Insulating gloves will be used in situations where touch voltage hazards could develop and in situations where the line conductor is to be handled at ground level and voltage transfer hazards could develop.

Generally the need to wear insulating gloves will be determined by the risk assessment process and/or the Engineer's Assessment. In many such instances insulating gloves will be worn in conjunction with insulating boots.

To protect insulating gloves from mechanical damage, an outer glove made from a suitable durable material must also be worn.

Insulating gloves are made from neoprene or rubber. A glove pair must have been tested to withstand 15 kV AC for one minute within the previous 12 months.

Australian Standard 2225 (1994) stipulates that insulating gloves are to be inspected immediately prior to use to ensure that they are clean and free from abrasions and cuts and then must be air (roll) tested for punctures. A method is outlined in below. Should there be any doubt concerning the condition of insulating gloves, they are to be replaced. The gloves must be cleaned, inspected and air tested before storing.

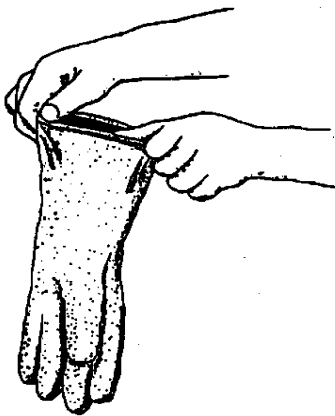

Step 1. Hold Glove Downward and Grasp Cuff.

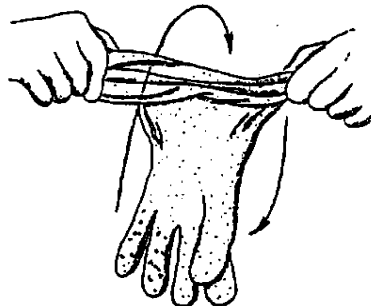

Step 2. Twirl Glove Towards Your Body to Trap Air Inside. Squeeze Glove To Look For Damage.

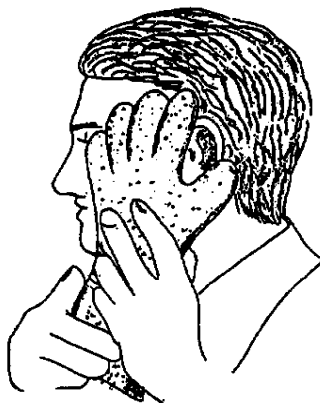

Step 3. Hold Glove To Face and Feel. Listen For Escaping Air or Immerse In Water and Watch For Bubbles.

Warning: A printed copy of this document may not be the current version. Please refer to the Wire to verify the current version.

Appendix B - Using an Approved Insulating Ladder for Access



Warning: A printed copy of this document may not be the current version. Please refer to the Wire to verify the current version.

Appendix C - Rolling Earths

Earths applied through conducting rollers and flexible earthing tails connected to the structure earthing system. They are use only during the process of running-out and/or tensioning conductor (or overhead earthwire) and are intended to protect persons from the hazards of induction.

SUPERSEDED

Warning: A printed copy of this document may not be the current version. Please refer to the Wire to verify the current version.