

# Maintaining safe and reliable operation of Molong substation

RIT-T Project Specification Consultation Report

Region: Central NSW

Date of issue: 2 April 2024

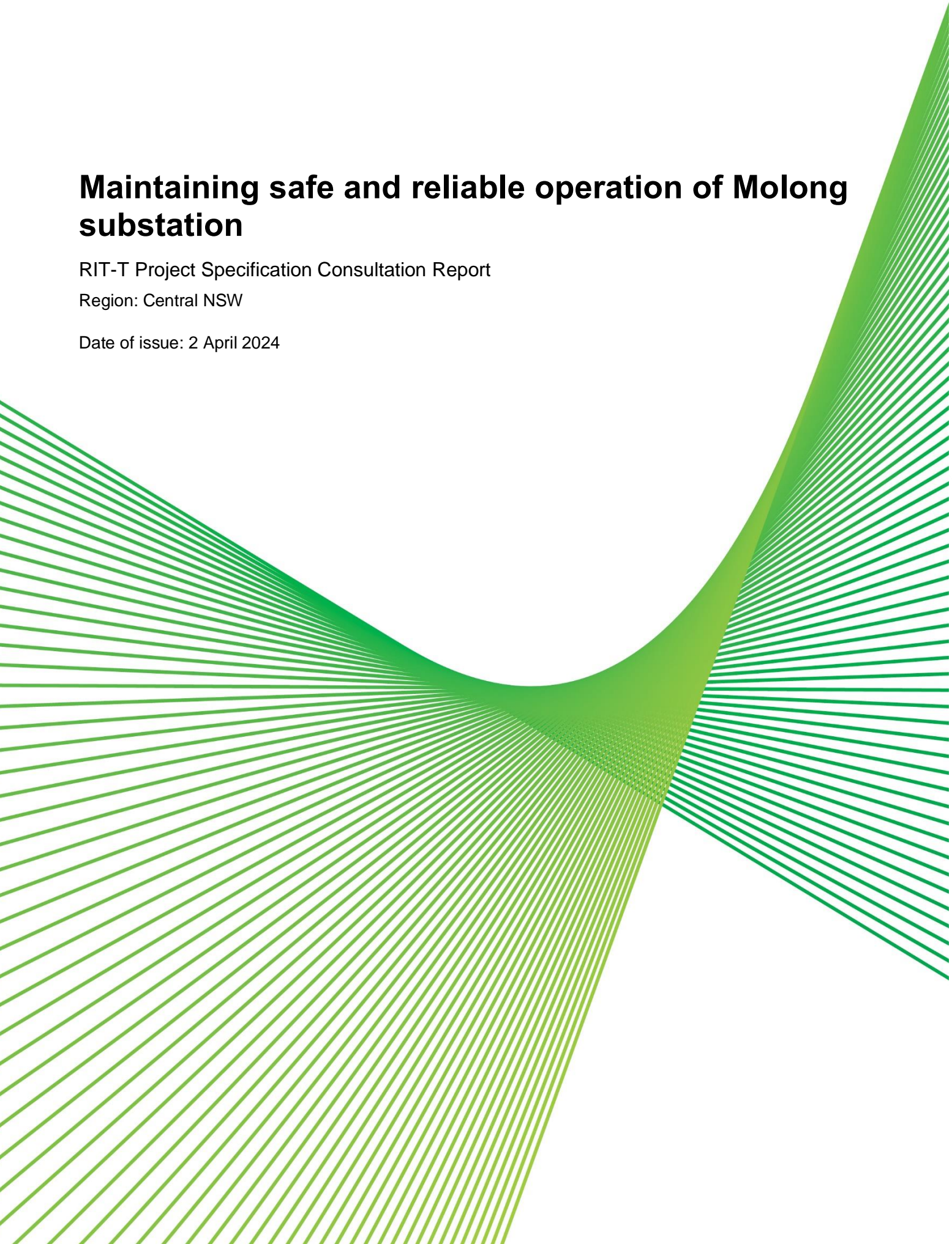

## Disclaimer

---

This suite of documents comprises Transgrid's application of the Regulatory Investment Test for Transmission (RIT-T) which has been prepared and made available solely for information purposes. It is made available on the understanding that Transgrid and/or its employees, agents and consultants are not engaged in rendering professional advice. Nothing in these documents is a recommendation in respect of any possible investment.

The information in these documents reflect the forecasts, proposals and opinions adopted by Transgrid at the time of publication, other than where otherwise specifically stated. Those forecasts, proposals and opinions may change at any time without warning. Anyone considering information provided in these documents, at any date, should independently seek the latest forecasts, proposals and opinions.

These documents include information obtained from the Australian Energy Market Operator (AEMO) and other sources. That information has been adopted in good faith without further enquiry or verification. The information in these documents should be read in the context of the Electricity Statement of Opportunities, the Integrated System Plan published by AEMO and other relevant regulatory consultation documents. It does not purport to contain all of the information that AEMO, a prospective investor, Registered Participant or potential participant in the National Electricity Market (NEM), or any other person may require for making decisions. In preparing these documents it is not possible, nor is it intended, for Transgrid to have regard to the investment objectives, financial situation and particular needs of each person or organisation which reads or uses this document. In all cases, anyone proposing to rely on or use the information in this document should:

- Independently verify and check the currency, accuracy, completeness, reliability and suitability of that information
- Independently verify and check the currency, accuracy, completeness, reliability and suitability of reports relied on by Transgrid in preparing these documents
- Obtain independent and specific advice from appropriate experts or other sources.

Accordingly, Transgrid makes no representations or warranty as to the currency, accuracy, reliability, completeness or suitability for particular purposes of the information in this suite of documents.

Persons reading or utilising this suite of RIT-T-related documents acknowledge and accept that Transgrid and/or its employees, agents and consultants have no liability for any direct, indirect, special, incidental or consequential damage (including liability to any person by reason of negligence or negligent misstatement) for any damage resulting from, arising out of or in connection with, reliance upon statements, opinions, information or matter (expressed or implied) arising out of, contained in or derived from, or for any omissions from the information in this document, except insofar as liability under any New South Wales and Commonwealth statute cannot be excluded.

## Privacy notice

Transgrid is bound by the *Privacy Act 1988 (Cth)*. In making submissions in response to this consultation process, Transgrid will collect and hold your personal information such as your name, email address, employer and phone number for the purpose of receiving and following up on your submissions.

Under the National Electricity Law, there are circumstances where Transgrid may be compelled to provide information to the Australian Energy Regulator (AER). Transgrid will advise you should this occur.

Transgrid's Privacy Policy sets out the approach to managing your personal information. In particular, it explains how you may seek to access or correct the personal information held about you, how to make a complaint about a breach of our obligations under the Privacy Act, and how Transgrid will deal with complaints. You can access the Privacy Policy here (<https://www.Transgrid.com.au/Pages/Privacy.aspx>).

## Executive summary

---

We are applying the Regulatory Investment Test for Transmission (RIT-T) to options for maintaining the safe and reliable operation of Molong Substation. Publication of this Project Specification Consultation Report (PSCR) represents the first step in the RIT-T process.

Molong 132/66kV Substation is located in Transgrid's central NSW network. It connects to Transgrid's 132kV Wellington, Manildra and Orange North substations. It also connects the Essential Energy 66kV distribution network and supports renewable generation from Molong Solar Farm.

As a customer connection point supplying Essential Energy in the Molong area, Molong substation supports the flow of electricity to local industries<sup>1</sup> and a residential population of approximately 13,000<sup>2</sup>. Transgrid's Central NSW network is also an area of interest for new renewable generation projects. Molong substation will continue to play a central role in the safe and reliable operation of the power system. New renewable generation with a combined output of 1,135 MW is in service in the region and a further 1,500 MW of renewable generation is committed or anticipated.

The condition of the Molong No.1 132kV transformer has been identified as reaching the end of its technical life leading to an increasing risk of failure which could result in reliability, safety, environment and financial consequences. Replacing the transformer would also require replacing associated switch gear and secondary systems such as switchgear, protection and control systems.

The purpose of this PSCR is to examine and consult on options to address the deterioration of the Molong No.1 transformer at Molong substation to reduce the likelihood of prolonged and involuntary load shedding in the Central NSW region and reduce the risk of safety and environmental hazards associated with a catastrophic failure.

### **Identified need: ensure the safe and reliable operation of Molong substation**

The identified need for this project is to maintain the safe and reliable operation of Molong substation and the broader transmission network in NSW by addressing the risk of failure of Molong substation's No. 1 power transformer.

The natural age of the No. 1 transformer will be 62 years in 2023/24, which is well above the 45-year expected useful life of a power transformer. Condition assessments performed through our routine maintenance program has shown degradation in the condition of the power transformer which will increase its risk of failure. Without intervention, other than ongoing business-as-usual maintenance, the asset is expected to deteriorate further and more rapidly. This will increase the risk of supply interruptions to our customers as well as safety, environmental and financial consequences.

---

<sup>1</sup> Major industries within Carbone include agriculture, mining and tourism and contribute towards the \$849.5 million annual economy and contribute significantly to the regional economy. Carbone Council. "Carbone Local Strategic Planning Statement 2020" 2020.10. Accessed 22 September 2021.  
<https://www.cabonne.nsw.gov.au/files/sharedassets/public/planning-and-development/local-strategic-planning-statement/cabonne-local-strategic-planning-statement-2020.pdf>

<sup>2</sup> The population of the Carbone Local Government Area is 13,386, as per the 2016 Census. Australian Bureau of Statistics, "2016 Census QuickStats", accessed 22 September 2021.  
[https://quickstats.censusdata.abs.gov.au/census\\_services/getproduct/census/2016/quickstat/LGA11400?opendocument](https://quickstats.censusdata.abs.gov.au/census_services/getproduct/census/2016/quickstat/LGA11400?opendocument)

We have classified this RIT-T as a ‘market benefits’ driven RIT-T as the economic assessment is not being progressed specifically to meet a mandated reliability standard but by the net benefits that are expected to be generated for end-customers.

## Two credible network options has been identified

We have identified two credible network options that meets the identified need from a technical, commercial, and project delivery perspective.<sup>3</sup> These options are summarised in the table below. A list of the specific assets with deteriorating condition to be addressed under Option 1 and Option 2 is included in section 3.2 and 3.3, respectively.

Table 1-1 Summary of the credible options

Option	Description	Capital costs (\$M, 2023/24)	Operating costs (\$M/yr, 2023/24)
Option 1	Replacement of the Molong No.1 transformer	7.08	0.001
Option 2	Refurbishment of the Molong No.1 transformer	1.29	0.002

## Non-network options are not expected to be able to assist with this RIT-T

We do not consider non-network options to be commercially and technically feasible to assist with meeting the identified need for this RIT-T. Non-network options will not mitigate the expected lost load, safety risks and environmental risks from failure of the No. 1 transformer.

## Option 1 delivers the highest net economic benefit and will meet NER requirements

We have assessed that Option 1 is the best performing option under all three reasonable scenarios considered in this PSCR. On a weighted basis, where each scenario is weighted equally, Option 1 is expected to deliver net benefits of approximately \$261.22 million.

## Draft Conclusion

This PSCR finds that Option 1 is the preferred option to address the identified need. Option 1 involves replacement of the No.1 Transformer at Molong substation due to the transformer having reached the end of its technical life.

The capital cost of this option is approximately \$7.08 million (in \$2023/24). The work will be undertaken over a single year period with all works expected to be completed by 2025/26. Routine operating and maintenance costs are estimated at approximately \$1,076 per annum (in \$2023/24).

## Exemption from preparing a Project Assessment Draft Report

Subject to the identification of additional credible options during the consultation period, publication of a Project Assessment Draft Report (PADR) is not required for this RIT-T as we consider that the conditions in clause 5.16.4(z1) of the NER exempting RIT-T proponents from providing a PADR have been met.

<sup>3</sup> As per clause 5.15.2(a) of the NER.

Specifically, production of a PADR is not required because:

- the estimated capital cost of the preferred option is less than \$46 million;<sup>4</sup>
- we have identified in this PSCR our preferred option and the reasons for that option, and noted that we will be exempt from publishing the PADR for our preferred option; and
- we consider that the preferred option and any other credible options do not have a material market benefit (other than benefits associated with changes in voluntary load curtailment and involuntary load shedding).

If an additional credible option that could deliver a material market benefit is identified during the consultation period, then we will produce a PADR that includes an assessment of the net economic benefit of each additional credible option.

If no additional credible options with material market benefits are identified during the consultation period, then the next step in this RIT-T will be the publication of a Project Assessment Conclusions Report (PACR) that addresses all submissions received, including any issues in relation to the proposed preferred option raised during the consultation period.<sup>5</sup>

## Submissions and next steps

We welcome written submissions on materials contained in this PSCR.

Submissions are due on 2 July 2024 and should be emailed to our Regulation team via [regulatory.consultation@transgrid.com.au](mailto:regulatory.consultation@transgrid.com.au).<sup>6</sup> In the subject field, please reference 'Molong substation renewal PSCR.' At the conclusion of the consultation process, all submissions received will be published on our website. If you do not wish for your submission to be made public, please clearly specify this at the time of lodgement.

Should we consider that no additional credible options were identified during the consultation period, we intend to produce a PACR that addresses all submissions received including any issues in relation to the proposed preferred option raised during the consultation period. Subject to additional credible options being identified, we anticipate publication of a PACR by August 2024.

---

<sup>4</sup> Varied from \$43m to \$46m based on the [AER Final Determination: Cost threshold review](#), November 2021.

<sup>5</sup> In accordance with NER clause 5.16.4(z2).

<sup>6</sup> Transgrid is bound by the Privacy Act 1988 (Cth). In making submissions in response to this consultation process, Transgrid will collect and hold your personal information such as your name, email address, employer and phone number for the purpose of receiving and following up on your submissions. If you do not wish for your submission to be made public, please clearly specify this at the time of lodgement. See Privacy Notice within the Disclaimer for more details.

# Contents

<b>Disclaimer .....</b>	<b>1</b>
Privacy notice .....	1
<b>Executive summary.....</b>	<b>3</b>
Identified need: ensure the safe and reliable operation of Molong substation .....	3
Two credible network options has been identified .....	4
Non-network options are not expected to be able to assist with this RIT-T .....	4
Option 1 delivers the highest net economic benefit and will meet NER requirements .....	4
Draft Conclusion .....	4
Exemption from preparing a Project Assessment Draft Report.....	4
Submissions and next steps.....	5
<b>1. Introduction.....</b>	<b>8</b>
1.1 Purpose of this report.....	8
1.2 Exemption from producing a Project Assessment Draft Report.....	9
1.3 Submissions and next steps .....	9
<b>2. The identified need.....</b>	<b>11</b>
2.1 Background to the identified need .....	11
2.2 Description of the identified need .....	12
2.3 Assumptions underpinning the identified need.....	13
2.3.1 Asset health and the probability of failure.....	13
2.3.2 Reliability risk .....	15
2.3.3 Safety risk.....	16
2.3.4 Environmental risk.....	16
2.3.5 Financial risk .....	16
<b>3. Options that meet the identified need .....</b>	<b>17</b>
3.1 Base case.....	17
3.2 Option 1 – Replacement of the Molong No.1 transformer.....	18
3.3 Option 2 – Refurbishment of the Molong No.1 transformer.....	19
3.4 Options considered but not progressed.....	20
3.5 No material inter-network impact is expected.....	20
<b>4. Technical characteristics for non-network options.....</b>	<b>22</b>
<b>5. Materiality of market benefits.....</b>	<b>23</b>

5.1	Avoided unserved energy is material.....	23
5.2	Wholesale electricity market benefits are not material .....	23
5.3	No other categories of market benefits are material .....	24
<b>6.</b>	<b>Overview of the assessment approach.....</b>	<b>26</b>
6.1	Assessment against the base case .....	26
6.2	Assessment period and discount rate.....	26
6.3	Approach to estimating option costs.....	27
6.4	Value of customer reliability .....	27
6.5	Three different scenarios have been modelled .....	27
6.6	Sensitivity analysis .....	29
<b>7.</b>	<b>Assessment of credible options .....</b>	<b>30</b>
7.1	Estimated gross benefits.....	30
7.2	Estimated costs.....	30
7.3	Estimated net economic benefits.....	30
7.4	Sensitivity testing .....	31
7.4.1	Optimal timing of the project .....	31
7.4.2	Scenario weights.....	32
7.4.3	Value of customer reliability .....	32
7.4.4	Network capital costs .....	33
7.4.5	Discount rate .....	34
<b>8.</b>	<b>Draft conclusion and exemption from preparing a PADR .....</b>	<b>36</b>
	<b>Appendix A Compliance checklist .....</b>	<b>37</b>
	<b>Appendix B Risk assessment framework .....</b>	<b>39</b>
	<b>Appendix C Asset Health and Probability of Failure.....</b>	<b>41</b>



# 1. Introduction

---

We are applying the Regulatory Investment Test for Transmission (RIT-T) to options for maintaining the safe and reliable operation of Molong substation. Publication of this Project Specification Consultation Report (PSCR) is the first step in the RIT-T process.

Molong 132/66kV Substation is located in Transgrid's central NSW network. It connects to Transgrid's 132kV Wellington, Manildra and Orange North substations. It also connects the Essential Energy 66kV distribution network and supports renewable generation from Molong Solar Farm.

As a customer connection point supplying Essential Energy in the Molong area, Molong substation supports the flow of electricity to local industries<sup>7</sup> and a residential population of approximately 13,000<sup>8</sup>. It is also an area of interest for new renewable generation projects. Molong substation will continue to play a central role in the safe and reliable operation of the power system. New renewable generation with a combined output of 1,135 MW is in service in the region and a further 1,500 MW of renewable generation is committed or anticipated.

The condition of the Molong No.1 transformer has been identified as reaching the end of its technical life leading to an increasing risk of failure which could result in reliability, safety, environment and financial consequences. Replacing the transformer would also require replacing associated switch gear and secondary systems such as protection and control systems.

The purpose of this PSCR is to examine and consult on options to address the deterioration of the Molong No.1 transformer at Molong substation to reduce the likelihood of prolonged and involuntary load shedding in the Central NSW region and reduce the risk of safety and environmental hazards associated with a catastrophic failure.

## 1.1 Purpose of this report

The purpose of this PSCR<sup>9</sup> is to:

- set out the reasons why Transgrid proposes that action be taken (the 'identified need')
- present the options that Transgrid is currently considering to address the identified need
- outline the technical characteristics that non-network options would need to provide
- summarise how we have assessed the options for addressing the identified need
- present the cost benefit assessment of all options for meeting the identified need
- identify the preferred option under the RIT-T assessment, and
- allow interested parties to make submissions and provide input to the RIT-T assessment.

---

<sup>7</sup> Major industries within Carbone include agriculture, mining and tourism and contribute towards the \$849.5 million annual economy and contribute significantly to the regional economy. Carbone Council. "Carbone Local Strategic Planning Statement 2020" 2020.10. Accessed 22 September 2021.

<https://www.carbone.nsw.gov.au/files/sharedassets/public/planning-and-development/local-strategic-planning-statement/carbone-local-strategic-planning-statement-2020.pdf>

<sup>8</sup> The population of the Carbone Local Government Area is 13,386, as per the 2016 Census. Australian Bureau of Statistics, "2016 Census QuickStats", accessed 22 September 2021.

[https://quickstats.censusdata.abs.gov.au/census\\_services/getproduct/census/2016/quickstat/LGA11400?opendocument](https://quickstats.censusdata.abs.gov.au/census_services/getproduct/census/2016/quickstat/LGA11400?opendocument)

<sup>9</sup> See Appendix A for the National Electricity Rules requirements.

## 1.2 Exemption from producing a Project Assessment Draft Report

Subject to the identification of additional credible options during the consultation period, publication of a Project Assessment Draft Report (PADR) is not required for this RIT-T as we consider that the conditions in clause 5.16.4(z1) of the NER exempting RIT-T proponents from providing a PADR have been met.

Specifically, production of a PADR is not required because:

- the estimated capital cost of the preferred option is less than \$46 million;<sup>10</sup>
- we have identified in this PSCR our preferred option and the reasons for that option, and noted that we will be exempt from publishing the PADR for our preferred option; and
- we consider that the preferred option and any other credible options do not have a material market benefit (other than benefits associated with changes in voluntary load curtailment and involuntary load shedding).

If an additional credible option that could deliver a material market benefit is identified during the consultation period, then we will produce a PADR that includes an assessment of the net economic benefit of each additional credible option.

If no additional credible options with material market benefits are identified during the consultation period, then the next step in this RIT-T will be the publication of a Project Assessment Conclusions Report (PACR) that addresses all submissions received, including any issues in relation to the proposed preferred option raised during the consultation period.<sup>11</sup>

## 1.3 Submissions and next steps

We welcome written submissions on materials contained in this PSCR.

Submissions are due on 2 July 2024 and should be emailed to our Regulation team via [regulatory.consultation@Transgrid.com.au](mailto:regulatory.consultation@Transgrid.com.au).<sup>12</sup> In the subject field, please reference 'Molong substation renewal PSCR.' At the conclusion of the consultation process, all submissions received will be published on our website. If you do not wish for your submission to be made public, please clearly specify this at the time of lodgement.

Should we consider that no additional credible options were identified during the consultation period, we intend to produce a PACR that addresses all submissions received including any issues in relation to the proposed preferred option raised during the consultation period. Subject to additional credible options being identified, we anticipate publication of a PACR by August 2024.

<sup>10</sup> Varied from \$43m to \$46m based on the [AER Final Determination: Cost threshold review](#), November 2021.

<sup>11</sup> In accordance with NER clause 5.16.4(z2).

<sup>12</sup> Transgrid is bound by the Privacy Act 1988 (Cth). In making submissions in response to this consultation process, Transgrid will collect and hold your personal information such as your name, email address, employer and phone number for the purpose of receiving and following up on your submissions. If you do not wish for your submission to be made public, please clearly specify this at the time of lodgement. See Privacy Notice within the Disclaimer for more details.

Figure 1-1 This PSCR is the first stage of the RIT-T process

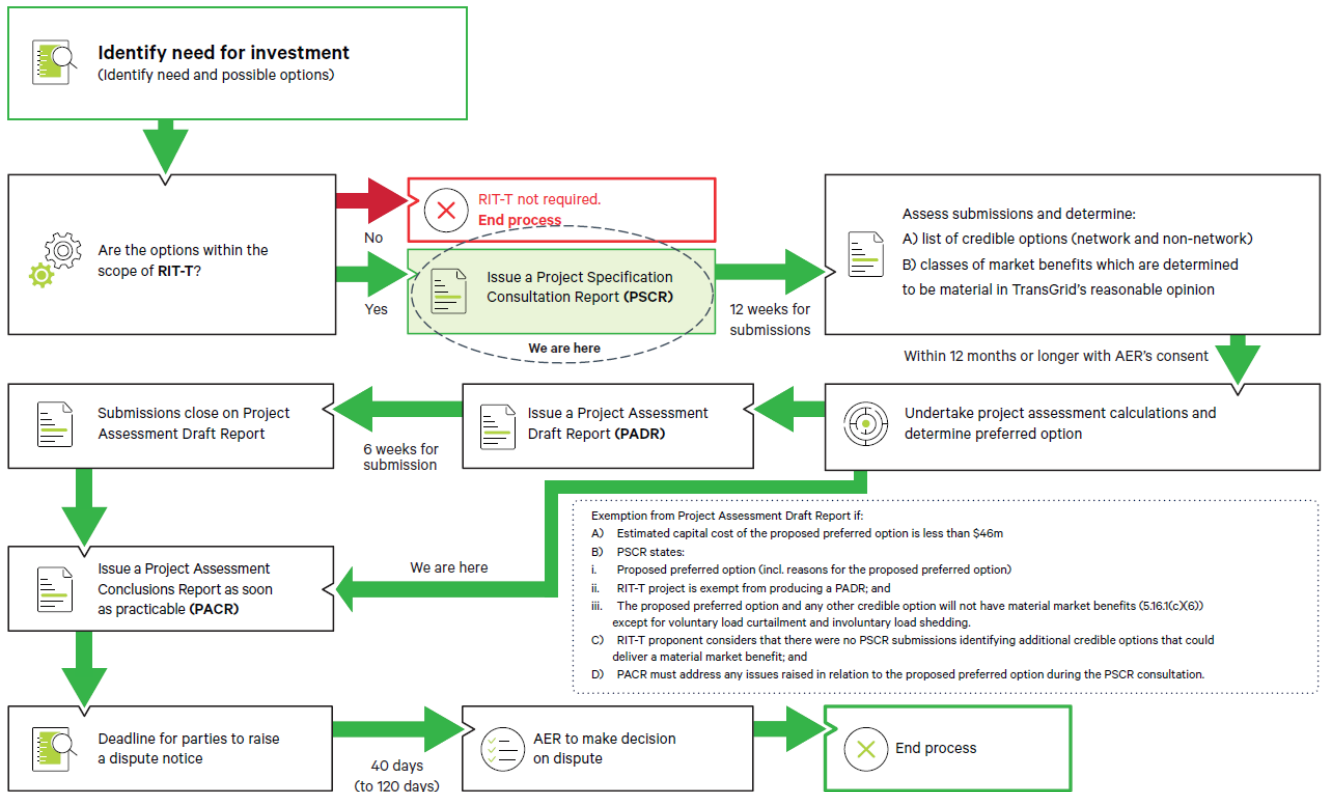

## 2. The identified need

### 2.1 Background to the identified need

Molong 132/66 kV Substation was commissioned in 1960 and forms a part of Transgrid’s network that serves the Central West region of NSW. Molong substation connects multiple 132 kV transmission lines — Line 945 to Wellington, Line 94P to Manildra and Line 94T to Orange North.

A map showing the location of Molong substation on our network is shown in Figure 2-1.

Figure 2-1 Location of Molong substation

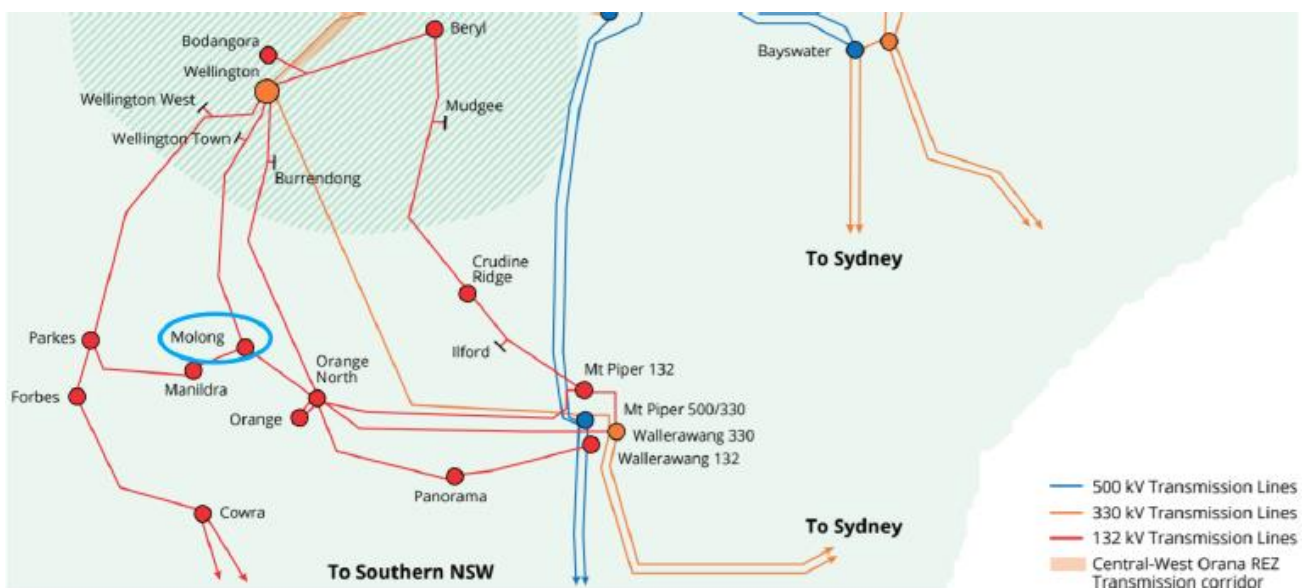

Transgrid’s Central NSW network is also an area of interest for new renewable generation projects. There are multiple renewable connection projects in various application stages, surrounding Molong Substation. There are also proposed large loads and existing load increases in the Parkes and Orange North area.

Molong substation will continue to play a central role in the safe and reliable operation of the power system in Central West as part of a route for power flow to supply large loads and renewable generators.

The existing electrical layout of Molong 132kV substation is shown in Figure 2-2.

Figure 2-2 Molong 132kV substation electrical layout

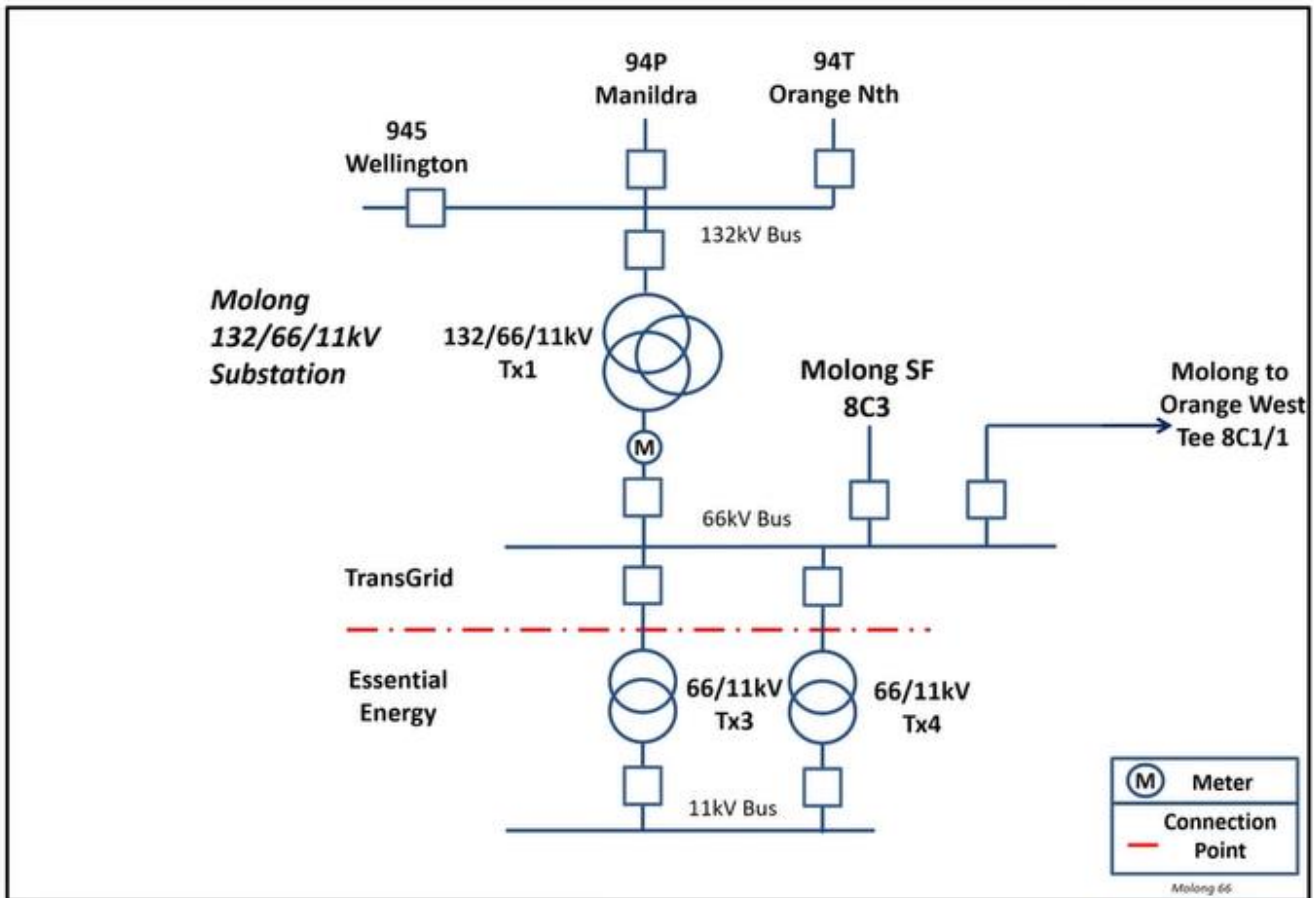

## 2.2 Description of the identified need

The identified need for this project is to maintain the safe and reliable operation of Molong substation and the broader transmission network in NSW by addressing the risk of failure of the Molong No.1 132kV transformer at Molong substation.

Condition assessments performed through our routine maintenance program has shown degradation in the condition of the power transformer which will increase its risk of failure. Without intervention, other than ongoing business-as-usual maintenance, the asset is expected to deteriorate further and more rapidly. This will increase the risk of supply interruptions to our customers as well as safety, environmental and financial consequences.

Power transformers are essential to the task of transmitting electricity as they change the voltage level between different sections of an electricity network. This enables electricity transportation infrastructure to be significantly more cost-effective, by reducing the power losses experienced between generators and consumers, while providing electricity at the appropriate voltage for end-users.

If the deteriorating asset condition of the power transformer is not addressed the likelihood of prolonged and involuntary load shedding in the Central NSW region will increase. Rectifying the worsening condition of the transformers will also reduce safety risks, as well as lower planned and unplanned corrective maintenance costs.

We have classified this RIT-T as a ‘market benefits’ driven RIT-T as the economic assessment is not being progressed specifically to meet a mandated reliability standard but by the net benefits that are expected to be generated for end-customers.

### 2.3 Assumptions underpinning the identified need

We adopt a risk cost framework to quantify and evaluate the risks and consequences of increased failure rates. Appendix B provides an overview of our Risk Assessment Methodology.

We note that the risk cost estimating methodology aligns with that used in our recently submitted Revised Revenue Proposal for the 2023-28 period. It reflects feedback from the Australian Energy Regulator (AER) on the methodology initially proposed in our initial Revenue Proposal.

Figure 2-3 summarises the increasing risk costs over the assessment period under the base case.

Figure 2-3 Estimated risk costs under the base case (central scenario)

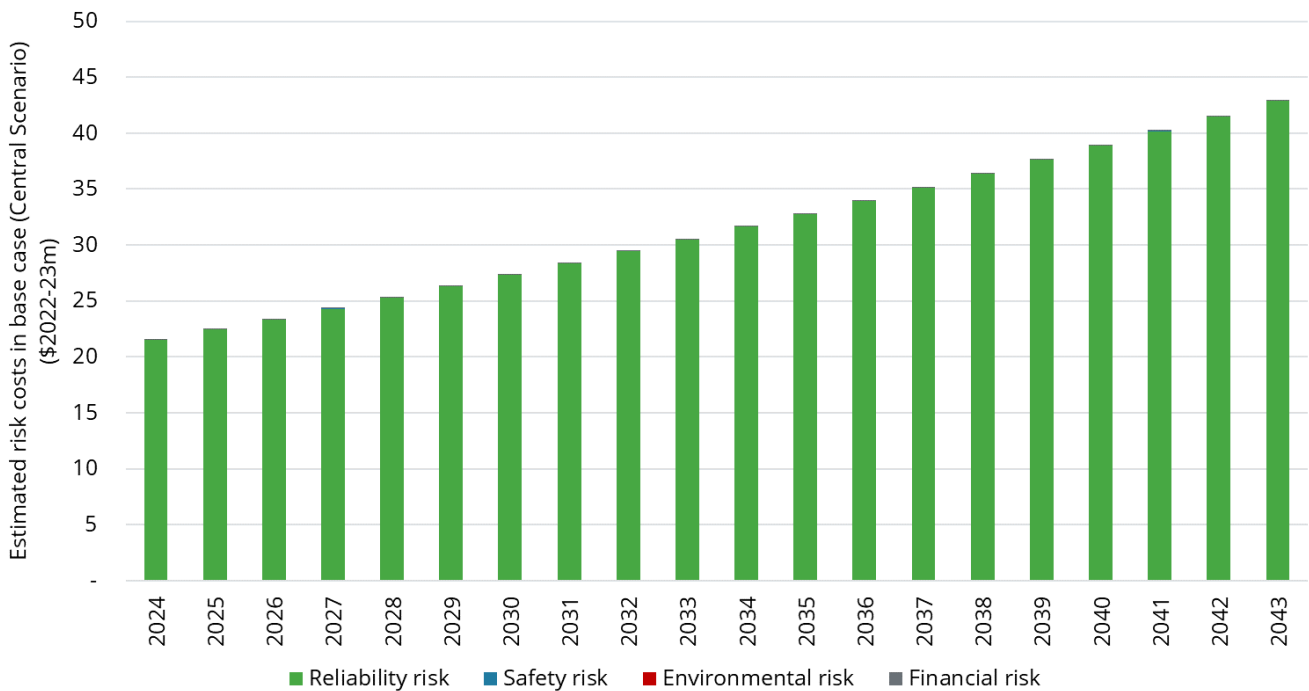

This section describes the assumptions underpinning our assessment of the risk costs, i.e., the value of the risk avoided by undertaking each of the credible options. The aggregate risk cost under the base case is currently estimated at around \$21.6 million/year in 2024 and it is expected to increase going forward if action is not taken and the transformer is left to deteriorate further (reaching approximately \$30 million/year by 2033 and over \$42 million/year by the end of the 20-year assessment period).

#### 2.3.1 Asset health and the probability of failure

Power transformers are essential for transmitting electricity as they change the voltage level between different sections of an electricity network. This enables electricity transportation infrastructure to be significantly more cost-effective, by reducing the power losses experienced between generators and

consumers, while providing electricity at the appropriate voltage for end-users. Molong substation connects Transgrid's 132kV and Essential Energy's 66kV network.

We have identified the following power transformer at Molong substation with condition deterioration that requires replacement or refurbishment.

Table 2-1 Current transformers considered under this RIT-T

Asset	Effective age (as at 2023/24)	Key issues
No. 1 Transformer	62	Condition deterioration

The Power transformer at Molong substation has reached the end of its economic life. As power transformers age, the following conditions materialise which increase the risk of asset failure:

- Degradation of the high voltage bushings and paper insulation system due to electrical stress
- Oil leaks due to degradation of seals and outer housing
- Lack of voltage control due to the poor condition of transformer and tap changer cubicles

Table 2-2 outlines the signs of deterioration at the Molong No.1 transformer.

Table 2-2 Condition issues with Molong No.1 transformer

Issue	Potential impact
Corrosive Sulphur	<p>Corrosive sulphur can form conductive compounds on insulating paper. Disrupting the integrity of the paper leading to thermal insulation failure or electrical breakdown between adjacent conductors.</p> <p>Sulphur compounds can also attack the silver coating on selector switching contacts, creating loose sections of conductive silver sulphide. This can result in a catastrophic failure of the tap changer and/or transformer.</p>
Aged Oil Impregnated Paper (OIP) Brushings	<p>The 132kV OIP bushings were installed in 1960 and equipped with porcelain insulators and a condenser-based core.</p> <p>Their advanced age makes them susceptible to failures from high over voltages and thermal stresses and humidity ingress.</p>
Paper insulation moisture	<p>The transformer insulation system is based on paper impregnated with insulating oil. Moisture acts to increase the rate of degradation of the paper insulating system. At high levels, it may compromise the insulation. The paper provides insulation and supports the structure of the transformer winding. Over time in conjunction with load and the presence of moisture, the paper becomes brittle. This may progress to the point where a mechanical shock caused by a through fault can result in electrical failure.</p>
Corrosion resulting in loss of oil due to leaks	<p>Corrosion resulting in leaks or leaking gaskets can cause loss of oil within the Transformer resulting in a catastrophic failure.</p> <p>Moisture and oxygen can also enter the transformer resulting in accelerated aging of the insulation resulting in failure.</p>

If left unreplaced or not refurbished, continued degradation in the condition of the asset will significantly increase the risk of asset failure and the risk of unplanned network outages. There will be an increased cost to replace the assets upon failure in a reactive fashion. A failure can also pose serious safety and environmental hazards. A failure of the power transformers can result in the risk of injuring people, cause collateral damage and outages of nearby services, and other environmental issues such as fires. Replacing the power transformers at Molong substation will reduce the risk of involuntary load shedding for customers in southern NSW and reduce the risk of safety and environmental hazards associated with any catastrophic failures occurring.

### 2.3.2 Reliability risk

We have considered the risk of unserved energy for customers following a failure of one or more of the high voltage and secondary systems assets identified in this PSCR. The likelihood of a consequence takes into account the likelihood of contingent planned/unplanned outages, the anticipated load restoration time (based on the expected time to undertake any repair work), and the load at risk (based on forecast demand). The monetary value is based on an assessment of the value of customer reliability, which measures the economic impact to affected customers of a disruption to their electricity supply.

Reliability risk makes up over 99 per cent of the total estimated risk cost in present value terms. The relative size of this risk is due to the high voltage transformer at the Molong substation having an effective age beyond its technical life. As the asset continue to age the probability of the transformer failing



increases. This increased probability of failure combined with a long load restoration time means that there is likely to be significant amounts of unserved energy over the assessment period without replacement or refurbishment of the asset.

### 2.3.3 Safety risk

This refers to the safety consequence to staff, contractors and/or members of the public of an asset failure. The likelihood of a consequence takes into account the frequency of workers on-site, the duration of maintenance and capital work on-site, and the probability and area of effect of an explosive asset failure. The monetary value takes into account the cost associated with fatality or injury compensation, loss of productivity, litigation fees, fines and any other related costs.

We manage and mitigate safety risk to ensure they are below risk tolerance levels or 'As Low As Reasonably Practicable' ('ALARP'), in accordance with our obligations under the *New South Wales Electricity Supply (Safety and Network Management) Regulation 2014* and our Electricity Network Safety Management System (ENSMS). Consistent with our ALARP obligations, we apply a disproportionality factor of 'six' to the public safety component and 'three' to the worker safety component of safety risk.

Safety risk makes up less than 1 per cent of the total estimated risk cost in present value terms.

### 2.3.4 Environmental risk

This refers to the environmental consequence (including bushfire risk) to the surrounding community, ecology, flora and fauna of an asset failure. The likelihood of a consequence takes into account the location of the site and sensitivity of surrounding areas, the volume and type of contaminant, the effectiveness of control mechanisms, and the likelihood and impact of bushfires. The monetary value takes into account the cost associated with damage to the environment including compensation, clean-up costs, litigation fees, fines and any other related costs.

Environmental risk makes up less than 1 per cent of the total estimated risk cost in present value terms.

### 2.3.5 Financial risk

This refers to the financial consequence of an asset failure. The likelihood of a consequence takes into account any compliance and regulatory factors which are not covered by the other categories. The monetary value takes into account the cost associated with disruption to business operations, any third party liability, and the cost of replacement or repair of the asset, including any temporary measures.

Financial risk makes up less than 1 per cent of the total estimated risk cost in present value terms.

### 3. Options that meet the identified need

This section describes the option(s) that we have explored to address the identified need, including the scope of each option and the associated costs.

We consider that there are two technically and commercially feasible options to address the identified need.<sup>13</sup> This involves replacement or refurbishment of the power transformer at Molong substation, as it has reached the end of its technical life based on an assessment of their age, condition, and technological obsolescence. The options are summarised in the table below. We do not consider non-network options to be technically or commercially feasible to assist with meeting the identified need for this RIT-T.

Table 3-1 Summary of credible options

Option	Description	Estimated capex (\$M, 2023/24)	Expected commission date (Financial year)
1	Replacement of the Molong No.1 transformer	7.08	2025/26
2	Refurbishment of the Molong No.1 transformer	1.29	2025/26

#### 3.1 Base case

Consistent with the RIT-T requirements, the assessment undertaken in this PSCR compares the costs and benefits of each credible option to a 'do nothing' base case. The base case is the (hypothetical) projected case if no action is taken, i.e.:<sup>14</sup>

*“The base case is where the RIT-T proponent does not implement a credible option to meet the identified need, but rather continues its 'BAU activities'. 'BAU activities' are ongoing, economically prudent activities that occur in absence of a credible option being implemented”*

Under the base case, no proactive capital investment is made to remediate the deterioration of the power transformer at Molong substation. The asset will continue to be operated and maintained under the current regime.

<sup>13</sup> As per clause 5.15.2(a) of the NER.

<sup>14</sup> AER, *Regulatory Investment Test for Transmission Application Guidelines*, August 2020, p. 21.

The table below provides a breakdown of the expected operating expenditure under the base case.

Table 3-2 Breakdown of operating expenditure under the base case (\$M, 2023/24)

Item	Operating expenditure (\$M, 2023/24)
Base case	0.002

Under the base case, increases to the regular maintenance regime will not be able to mitigate the risk of asset failure due to continued deterioration in asset condition. This will lead to an increase in the probability of failure at Molong substation. Rectification of an asset failure will take longer due as Transgrid does not hold a like for like spare transformer. A suitable spare will need be transported and assembled to restore supply. This will lead to an increase in the outage duration in the event of a transformer failure at Molong substation.

These factors will increase the risk of prolonged and frequent involuntary load shedding for end-customers. We have estimated that the cost of involuntary load shedding due to asset failure at Molong substation will increase from approximately \$11.9 million in 2023/24 to approximately \$25 million in 2042/43 (in \$2023/24). The above factors will also expose us and our end-customers to greater environmental, safety and financial risks associated with catastrophic asset failure, such as increased risk of explosive failure resulting in injury to nearby people and collateral damage to nearby assets. We have estimated that environmental, safety and financial risks costs under the base case will be approximately \$37,000 in 2023/24 and increase to \$74,000 in 2042/43 (in \$2023/24).

### 3.2 Option 1 – Replacement of the Molong No.1 transformer

Option 1 involves the replacement of the Molong No.1 transformer with a new 132/66 kV 30 MVA transformer.

This option involves:

- Installation of a new 30MVA power transformer and auxiliary transformer.
- Installation of new associated switchgear, protection and control systems (secondary systems);
- Modifying the oil containment system; and
- Civil works.

The new transformer will be installed in a new compound with associated bays to maintain reliability during construction. The old transformer will then be decommissioned and disposed of once the new transformer is in-service.

Implementation of Option 1 is expected to reduce the probability of failure of the power transformer at Molong substation. This will reduce the frequency and duration of involuntary load shedding associated with the failure of this asset. Option 1 will also reduce the risk of asset failure, which will in turn reduce associated environmental, safety and financial risk costs.

The work will be undertaken a single year period with all works expected to be completed within the 2025/26 period. The capital cost of this option is approximately \$7.08 million (in \$2023/24). Table 3-3 below provides an overview of estimated capital cost, while Table 3-4 breaks down the capital cost according to whether the cost will be labour, material or expenses.

Table 3-3 Capital cost of Option 1 by financial year (\$M, 2023/24)

Option	Description	Estimated capex (\$M, 2023/24)	Expected commission date (Financial year)
1	Replacement of the Molong No.1 transformer	7.08	2025/26

Table 3-4 Capital cost of Option 1 by labour, expenses and materials (\$M, 2023/24)

Capital cost	Labour	Expenses	Materials
Total	1.56	2.52	3.00

The routine operating and maintenance costs are estimated at approximately \$0.001 million per annum (in \$2023/24). We expect that the new transformer will have an asset life of 45 years.

All works will be completed in accordance with the relevant standards and components shall be replaced to have minimal modification to the wider transmission network. Necessary outages of relevant assets in service will be planned appropriately in order to complete the works with minimal impact on the network.

### 3.3 Option 2 – Refurbishment of the Molong No.1 transformer

Option 2 involves the refurbishment of the Molong No.1 transformer.

This option involves:

- Replacement of high voltage, low voltage and tertiary voltage bushings
- Oil treatment and/or replacement
- Corrosion repair, leak repair and repainting
- Major overhaul of the tap changer and selector
- Conservator modifications and/or repairs.

This would require a 12-16 week outage of the No.1 transformer, during this period the load would need to be supplied via the Essential Energy 66kV network.

Refurbishment is expected to improve condition issues associated with the bushings, insulating oil quality, gasket leaks and tap changer components. It cannot address or improve the quality of the paper insulation, eliminate gas generation, ageing in the core, improve winding clamping pressure or eliminate all sulphur compounds bonded to the tap changer contacts.

The refurbishment is expected to result in a reduction in the effective age of the transformer by five years. Given that the useful life of a transformer is around 45 years, the refurbishment will only provide a minor reduction. The majority of the reliability, safety and environmental risk will remain even after the refurbishment and will only be addressed by replacement.

The work will be undertaken across a single year period with all works expected to be completed to be completed within the 2025/26 period. The capital cost of this option is approximately \$1.29 million (in \$2023/24). Table 3-3 below provides an overview of the estimated capital cost, while Table 3-4 breaks down the capital cost according to whether the cost will be labour, material or expenses.

Table 3-5 Capital cost of Option 2 by financial year (\$M, 2023/24)

Option	Description	Estimated capex (\$M, 2023/24)	Expected commission date (Financial year)
1	Refurbishment of the Molong No.1 transformer	1.29	2025/26

Table 3-6 Capital cost of Option 1 by labour, expenses and materials (\$M, 2023/24)

Capital cost	Labour	Expenses	Materials
Total	0.90	0.27	0.12

The routine operating and maintenance costs are estimated at approximately \$0.002 million per annum (in \$2023/24). The refurbishment will improve the asset life of the transformer by five years.

All works will be completed in accordance with the relevant standards and components shall be replaced to have minimal modification to the wider transmission network. Necessary outages of relevant assets in service will be planned appropriately in order to complete the works with minimal impact on the network.

### 3.4 Options considered but not progressed

We have also considered whether other options could meet the identified need. Reasons these options were not progressed are summarised in Table 3-7.

Table 3-7 Options considered but not progressed

Option	Reason(s) for not progressing
Increased maintenance or inspections	The condition issues have already been identified and cannot be rectified through increased maintenance or inspections, and therefore is not technically feasible to address the need.
Asset retirement	This option is not technically or economically feasible due to the requirement to maintain the existing network reliability.
Non-network solutions	It is not technically feasible for non-network options to be commercially feasible to assist with meeting the identified need.

### 3.5 No material inter-network impact is expected

We have considered whether the credible options listed above are expected to have material inter-regional impact.<sup>15</sup> A 'material inter-network impact' is defined in the NER as:<sup>16</sup>

*“A material impact on another Transmission Network Service Provider’s network, which impact may include (without limitation): (a) the imposition of power transfer constraints within another Transmission Network Service Provider’s network; or (b) an adverse impact on the quality of supply in another Transmission Network Service Provider’s network.”*

<sup>15</sup> As per clause 5.16.4(b)(6)(ii) of the NER.

<sup>16</sup> Definition of 'material inter-network impact,' in the Glossary to the NER.

By reference to AEMO's screening test for an inter-network impact,<sup>17</sup> a material inter-regional impact may arise if a credible option:

- is expected to change power transfer capability between transmission networks or in another TNSP's network by more than the minimum of 3 per cent of the maximum transfer capability and 50 MW
- is expected to result in an increase in fault level by more than 10 MVA at any substation in another TNSP's network; or
- involves either a series capacitor or modification in the vicinity of an existing series capacitor.

As none of these criteria are satisfied for this RIT-T, we consider that there are no material inter-network impacts associated with any of the credible options considered.

---

<sup>17</sup> Inter-Regional Planning Committee. "Final Determination: Criteria for Assessing Material Inter-Network Impact of Transmission Augmentations." Melbourne: Australian Energy Market Operator, 2004. Appendix 2 and 3. Accessed 23 June 2021. [https://aemo.com.au/-/media/files/electricity/nem/network\\_connections/transmission-and-distribution/170-0035-pdf.pdf](https://aemo.com.au/-/media/files/electricity/nem/network_connections/transmission-and-distribution/170-0035-pdf.pdf)

## 4. Technical characteristics for non-network options

---

We do not consider non-network options to be commercially and technically feasible to assist with meeting the identified need for this RIT-T. The objective of this identified need is to address the deterioration of the Molong No.1 transformer at Molong substation to reduce the likelihood of prolonged and involuntary load shedding in the Central NSW region and reduce the risk of safety and environmental hazards associated with a catastrophic failure.

We do not expect that non-network options are able to meet the identified need, irrespective of their type, size, operating profile and location. Any non-network solution for this need is expected to only add to the costs of this option without providing any net benefits.

## 5. Materiality of market benefits

---

This section outlines the categories of market benefits prescribed in the National Electricity Rules (NER) and whether they are considered material for this RIT-T.<sup>18</sup>

### 5.1 Avoided unserved energy is material

We consider that changes in involuntary load shedding are expected to be material for the credible options outlined in this PSCR. In the base case, involuntary load shedding would be expected to occur following a failure of the power transformer at Molong substation which would require taking affected primary assets, such as lines and transformers, out of service.

The probability of asset failure is expected to increase over time as the condition of the relevant assets continue to deteriorate. This is expected to increase the frequency of outages. Rectification of an asset failure will take longer due as Transgrid does not hold a like for like spare transformer. A suitable spare will need be transported and assembled to restore supply. This will lead to an increase in the outage duration in the event of a transformer failure at Molong substation.

We have estimated expected unserved energy under the base case and the credible Options. These forecasts are based on probabilistic planning studies of failure rates and repair times. Option 1 significantly reduces the amount of expected unserved energy that would occur, while Option 2 will reduce expected unserved energy by a lesser amount. The avoided unserved energy for a credible option is calculated as the difference between the expected unserved energy under the base case and the expected unserved energy under the Option.

### 5.2 Wholesale electricity market benefits are not material

The AER has recognised that if the credible options will not have an impact on the wholesale electricity market, then a number of classes of market benefits will not be material in the RIT-T assessment, and so do not need to be estimated.

We determine that the credible options in this PSCR will not affect network constraints between competing generating centres and are therefore not expected to result in any change in dispatch outcomes and wholesale market prices. We therefore consider that the following classes of market benefits are not material for this RIT-T assessment:

- changes in fuel consumption arising through different patterns of generation dispatch;
- changes in voluntary load curtailment (since there is no impact on pool price);
- changes in costs for parties other than the RIT-T proponent;
- changes in ancillary services costs; and
- competition benefits

---

<sup>18</sup> The NER requires that all classes of market benefits identified in relation to the RIT-T are included in the RIT-T assessment, unless the TNSP can demonstrate that a specific class (or classes) is unlikely to be material in relation to the RIT-T assessment for a specific option – NER clause 5.15A.2(b)(5). See Appendix A for requirements applicable to this document.



### 5.3 No other categories of market benefits are material

In addition to the classes of market benefits identified above, the NER also requires us to consider the following classes of market benefits, listed in Table 5-1, arising from each credible option.<sup>19</sup> We consider that none of the classes of market benefits listed are material for this RIT-T assessment for the reasons in Table 5-1.

Table 5-1: Reasons non-wholesale electricity market benefits categories are considered not material

Market benefits	Reason
Differences in the timing of unrelated network expenditure	The credible options considered are unlikely to affect decisions to undertake unrelated expenditure in the network. Consequently, material market benefits will neither be gained nor lost due to changes in the timing of expenditure from any of the options considered.
Option value	<p>We note the AER’s view that option value is likely to arise where there is uncertainty regarding future outcomes, the information that is available is likely to change in the future, and the credible options considered by the TNSP are sufficiently flexible to respond to that change.<sup>20</sup></p> <p>We also note the AER’s view that appropriate identification of credible options and reasonable scenarios captures any option value, thereby meeting the NER requirement to consider option value as a class of market benefit under the RIT-T.<sup>21</sup></p> <p>We do not consider there to be any option value with the options considered in this PSCR. Additionally, a significant modelling assessment would be required to estimate the option value benefits which would be disproportionate to the potential additional benefits for this RIT-T. Therefore, we have not estimated additional option value benefit.</p>
Changes in network losses	We do not expect any material difference in transmission losses between options.

On 21 September 2023, the National Energy Objective (NEO) in the National Energy Laws (NEL) was amended to incorporate a new emissions reduction objective.<sup>22,23</sup> Prior to the commencement of the amended Act, the NEO referred to the long-term interests of energy consumers with respect to price, quality, safety, reliability and security of supply of energy. The emissions reduction objective introduced by the Act adds reference to the long-term interests of energy consumers with respect to the achievement of targets set by a participating jurisdiction for reducing Australia’s greenhouse gas emissions, or that are likely to contribute to reducing Australia’s greenhouse gas emissions. The National Energy Rules were amended to give effect to the updated NEO on 1 February 2024.<sup>24</sup>

Transgrid supports greater consideration of emissions reduction within network planning and investment frameworks. These changes enable network planning and investment frameworks to support the

<sup>19</sup> NER, clause 5.15A.2(b)(4)-(6).

<sup>20</sup> AER, *Regulatory Investment Test for Transmission Application Guidelines*, October 2023, p.57.

<sup>21</sup> AER, *Regulatory Investment Test for Transmission Application Guidelines*, October 2023, p.57.

<sup>22</sup> The amended Act refers to the Statutes Amendment (National Energy Laws) (Emissions Reduction Objectives) Act 2023 (SA)

<sup>23</sup> The Act amends the National Electricity Law (NEL), National Gas Law (NGL) and National Energy Retail Law (NERL) by incorporating a new emissions reduction objective into the national energy objectives contained in each of these laws. The national energy objectives comprise the National Electricity Objective set out in the NEL, the National Gas Objective set out in the NGL, and the National Energy Retail Objective set out in the NERL.

<sup>24</sup> Government of South Australia, National Electricity (South Australia) Act 1996—21.9.2023, clause 40 s.4(b)

achievement of the Commonwealth Government's net zero targets. Transgrid has set our own science-based targets to cut emissions and decarbonise our business. These include:

- Reducing Scope 1 and 2 emissions by 60 per cent by 2030, compared with a base year of 2021 and net zero by 2040.
- Reducing Scope 3 emissions from Purchased Goods and Services, and Capital Goods by 48 per cent for every million dollars that we spend on these two categories by 2030, compared with a base year of 2021, and net zero by 2050.

We have applied the updated NEO to this RIT-T assessment and do not consider there to be any material changes to greenhouse gas emissions under the proposed options, as the proposed options are unlikely to significantly alter the generation mix across the NEM. Nonetheless, Transgrid is working to understand how to assess the quantum and value of expected changes in greenhouse gas emissions. Outcomes from this emissions modelling will be considered and presented within the PACR. Where possible and practical, we will refine this approach and any results following updated guidance being provided by the AER on RIT-T related emissions reduction assessments.

## 6. Overview of the assessment approach

---

This section outlines the approach that we have applied in assessing the net benefits associated with each of the credible options against the base case.

### 6.1 Assessment against the base case

The costs and benefits of each option in this document are compared against a 'do nothing' base case. Under this base case, no proactive capital investment is made to remediate the deterioration of the high voltage and secondary systems assets at Molong substation. We incur regular and reactive maintenance costs, and environmental, safety and financial related risks costs, that are caused by the failure of assets at Molong substation. In addition, there would be a small avoided cost of routine operating and maintenance costs in Option 1 compared to the base case.

We note that this course of action is not expected in practice. However, this approach has been adopted since it is consistent with AER guidance on the base case for RIT-T applications.<sup>25</sup>

### 6.2 Assessment period and discount rate

The RIT-T analysis considers a 20-year assessment period from 2023/24 to 2042/43. A 20-year period takes into account the size, complexity and expected asset life of the secondary systems and provides a reasonable indication of the costs and benefits over a long outlook period.

Where the capital components of the credible options have asset lives extending beyond the end of the assessment period, the NPV modelling includes a terminal value to capture the remaining asset life. This ensures that the capital cost of long-lived options over the assessment period is appropriately captured, and that all options have their costs and benefits assessed over a consistent period, irrespective of option type, technology or asset life. The terminal values have been calculated based on the undepreciated value of capital costs at the end of the analysis period and expected operating and maintenance cost for the remaining asset life. As a conservative assumption, we have effectively assumed that there are no additional cost and benefits after the analysis and period.

A real, pre-tax discount rate of 7 per cent has been adopted in all scenarios presented in this PSCR, consistent with AEMO's 2023 Inputs, Assumptions and Scenarios Consultation Report (IASR).<sup>26</sup> The RIT-T requires that sensitivity testing be conducted on the discount rate and that the regulated weighted average cost of capital (WACC) be used as the lower bound. We have therefore tested the sensitivity of the Central scenario results to a lower bound discount rate of 3 per cent.<sup>27</sup> We have also adopted an upper bound discount rate of 10.5 per cent (i.e., AEMO's 2023 Inputs, Assumptions and Scenarios Report).<sup>28</sup>

---

<sup>25</sup> Transgrid notes that the AER RIT-T Guidelines state that the base case is where the RIT-T proponent does not implement a credible option to meet the identified need, but rather continues its 'BAU activities'. The AER define 'BAU activities' as ongoing, economically prudent activities that occur in the absence of a credible option being implemented. (See: AER, *Regulatory Investment Test for Transmission Application Guidelines*, August 2020, p.21).

<sup>26</sup> AEMO '2023 Inputs, Assumptions and Scenarios Report', July 2023, p 123.

<sup>27</sup> This is equal to WACC (pre-tax, real) in the latest final decision for a transmission business in the NEM (Transgrid) as of the date of this analysis, see: <https://www.aer.gov.au/networks-pipelines/determinations-access-arrangements/transgrid-determination-2023%E2%80%9328/final-decision>

<sup>28</sup> AEMO '2023 Inputs, Assumptions and Scenarios Report', July 2023, p 123.

### 6.3 Approach to estimating option costs

We have estimated the capital and operating costs of the options based on the scope of works necessary together with costing experience from previous projects of a similar nature.

The cost estimates are developed using our 'MTWO' cost estimating system. This system utilises historical average costs, updated by the costs of the most recently implemented project with similar scope. All estimates in MTWO are developed to deliver a 'P50' portfolio value for a total program of works (ie, there is an equal likelihood of over- or under-spending the estimate total).<sup>29</sup>

We estimate that the actual cost is within +/- 25 per cent of the central capital cost. An accuracy of +/-25 per cent is consistent with industry best practice and aligns with the accuracy range of a 'Class 4' estimate, as defined in the Association for the Cost Engineering classification system. In line with recent changes to the AER RIT Guidelines regarding cost estimation transparency<sup>30</sup>, we consider this cost estimate is fit for purpose given the PSCR is the earliest stage of the RIT-T process.

All cost estimates are prepared in real, 2023/24 dollars based on the information and pricing history available at the time that they were estimated. The cost estimates do not include or forecast any real cost escalation for materials.

Routine operating and maintenance costs are based on works of similar nature. Given that there is a minor incremental routine operating and maintenance costs saving in Option 1 compared to the base case, this is a net benefit in the assessment.

### 6.4 Value of customer reliability

Consistent with the AER's RIT-T Guideline, we have developed VCR estimates that are based on the estimates developed and consulted on by the AER, weighted to reflect the mix of customers that are likely to be affected by the options.

We have applied a NSW-wide VCR value based on the estimates developed and consulted on by the AER.<sup>31</sup> We have used this VCR as we consider this reasonably reflects the mix of customers supplied from the Molong substation, which includes residential, agricultural and industrial customers.

### 6.5 Three different scenarios have been modelled

The RIT-T must include any of the ISP scenarios from the most recent IASR that are relevant unless:<sup>32</sup>

- the RIT-T proponent demonstrates why it is necessary to vary, omit or add a reasonable scenario to what was in the most recent IASR, and
- the new or varied reasonable scenarios are consistent with the requirements for reasonable scenarios set out in the RIT-T instrument.

<sup>29</sup> For further detail on our cost estimating approach refer to section 7 of our [Augmentation Expenditure Overview Paper](#) submitted with our 2023-28 Revenue Proposal.

<sup>30</sup> AER, *Final amendments – Cost benefit analysis guidelines and RIT application guidelines – Explanatory statement*, October 2023, pp. 15-17.

<sup>31</sup> AER, *Values of Customer Reliability, Final Report on VCR Values*, December 2019. Escalated to December 2023 values. Based on CPI inflation published by the AER in its [annual VCR updates](#).

<sup>32</sup> AER, *Regulatory investment test for transmission*, August 2020, clause 20(b).

The AER's RIT-T Guidelines clarifies that the number and choice of reasonable scenarios must be appropriate to the credible options under consideration, and that the choice of reasonable scenarios must reflect any variables or parameters that are likely to affect the ranking or sign of the net benefit of any credible option.<sup>33</sup>

For the purposes of this RIT-T, we consider that the ISP scenarios are not relevant. The key input parameter that is likely to affect the ranking or sign of the net market benefits of the credible options is the probability of failure and consequence of failure of the assets at Molong substation. The probability and consequence is assessed by reference to the condition of the asset under consideration and the reliability, safety, environmental and financial consequences. These are independent from the assumptions underpinning the ISP scenarios. It follows that adopting the ISP scenarios would not be consistent with adopting scenarios that reflect parameters that could reasonably change the ranking or sign of the net market benefits of the credible options.

In line with the RIT-T Guideline, we have constructed reasonable alternative scenarios. To do this, we developed a **Central Scenario** which reflects our best estimate of each of the modelling parameters, including the asset risk (probability of failure and consequence of failure), expected unserved energy, and capital and operating costs. We developed the Central Scenario around a static model of demand scenarios, described further in our Section A.3 of our [Network Asset Criticality Framework](#). We consider that this approach is appropriate since it materially reduces the computational effort required, and since differences in demand forecasts will not materially affect the sign or ranking of the credible options.

As indicated above, we consider that the key input parameter that is likely to affect the ranking or sign of the net market benefits of the credible options is the asset failure risk of the identified high voltage and secondary systems assets. We do not consider that variations in other parameters of the Central Scenario are likely to affect the outcome of the RIT-T assessment. In view of this, we have developed additional reasonable scenarios that reflect variations in the asset risk while holding other parameters the same as the Central Scenario.

Specifically, we have developed the following additional scenarios:

- A **High Risk Costs Scenario**, where the asset failure risk is 25% higher than in the Central Scenario. This higher risk would be expected to increase the frequency and duration of outages, and safety, environmental and financial risk costs, in the base case (as compared with the Central Scenario). We have modelled this scenario by increasing our estimate of gross benefits associated with avoided unserved energy and risk costs in this scenario by 25%.
- A **Low Risk Costs Scenario**, where the asset failure risk is 25% lower than in the Central Scenario. This lower failure risk would be expected to reduce the frequency and duration of outages, and safety, environmental and financial risk costs, in the base case (as compared with the Central Scenario). We have modelled this scenario by reducing our estimate of gross benefits associated with avoided unserved energy and risk costs in this scenario by 25%.

The NPV results in this PSCR are reported for each scenario, as well as on a weighted basis. As we have no evidence or rationale for assigning a higher probability for one reasonable scenario over another, we have weighted each reasonable scenario equally.<sup>34</sup>

<sup>33</sup> AER, *Regulatory investment test for transmission: Application guidelines*, October 2023, p.42-44.

<sup>34</sup> As per: AER, *Regulatory investment test for transmission: Application guidelines*, October 2023, p.50.

A summary of the key variables in each scenario is provided in the table below.

Table 6-1 Summary of scenarios

Variable / Scenario	Central scenario	Low risk costs scenario	High risk costs scenario
Scenario weighting	1/3	1/3	1/3
Discount rate	7.0%	7.0%	7.0%
VCR (\$2023/24 m)	\$54.95/kWh	\$54.95/kWh	\$54.95/kWh
Network capital costs	Base estimate	Base estimate	Base estimate
Avoided unserved energy	Base estimate	Base estimate - 25%	Base estimate + 25%
Safety, environmental and financial risk benefit	Base estimate	Base estimate - 25%	Base estimate + 25%
Avoided routine operating and maintenance costs	Base estimate	Base estimate	Base estimate

## 6.6 Sensitivity analysis

In addition to the scenario analysis, we have also considered the robustness of the outcome of the cost benefit analysis through undertaking various sensitivity testing.

The range of factors tested as part of the sensitivity analysis in this PSCR are:

- Optimal timing of the project
- Alternate scenario weights
- Higher or lower VCRs
- Higher or lower network capital costs of the credible options
- Alternate commercial discount rate assumptions.

The above list of sensitivities focuses on the key variables that could impact the identified preferred option. The results of the sensitivity tests are set out in section 7.4.

In addition, we have also sought to identify the 'boundary value' for key variables beyond which the outcome of the analysis would change.

## 7. Assessment of credible options

This section outlines the assessment we have undertaken of the credible options. The assessment compares the costs and benefits of the option to the base case. The benefits of each credible option are represented by reduction in costs or risks compared to the base case.

### 7.1 Estimated gross benefits

The table below summarises the present value of the gross benefit estimates for each credible option relative to the base case. The results have been presented separately for each credible scenario, and on a weighted basis.

The benefits included in this assessment are:

- avoided involuntary load shedding;
- reduction in safety, environmental and financial risks; and
- avoided routine operating and maintenance costs.

Table 7-1 NPV of gross economic benefits relative to the base case (\$2023/24 m)

Option	Central scenario	Low risk costs scenario	High risk costs scenario	Weighted scenario
<i>Scenario weighting</i>	1/3	1/3	1/3	
Option 1	265.65	199.24	332.06	265.65
Option 2	77.58	58.18	96.97	77.69

Option 1 produces larger gross benefits under all scenarios.

### 7.2 Estimated costs

The table below summarises the present value of capital costs of each credible option relative to the base case. The results have been presented separately for each credible scenario, and on a weighted basis.

Table 7-2 NPV of capital costs relative to the base case (\$2023/24 m)

Option	Central scenario	Low risk costs scenario	High risk costs scenario	Weighted scenario
<i>Scenario weighting</i>	1/3	1/3	1/3	
Option 1	6.18	6.18	6.18	6.18
Option 2	1.13	1.13	1.13	1.13

Option 2 is lower cost under all scenarios.

### 7.3 Estimated net economic benefits

The net economic benefits are calculated as the estimated gross benefits less the estimated costs plus the terminal value. The table below summarises the present value of the net economic benefits for each credible option. The results have been presented separately for each reasonable scenario, and on a weighted basis.

Table 7-3 NPV of net economic benefits relative to the base case (\$2023/24 m)

Option	Central scenario	Low risk costs scenario	High risk costs scenario	Weighted scenario
<i>Scenario weighting</i>	1/3	1/3	1/3	
Option 1	261.22	194.80	327.63	261.22
Option 2	76.56	57.14	95.98	76.56

Figure 7-1 NPV of net economic benefits (\$2023/24 m)

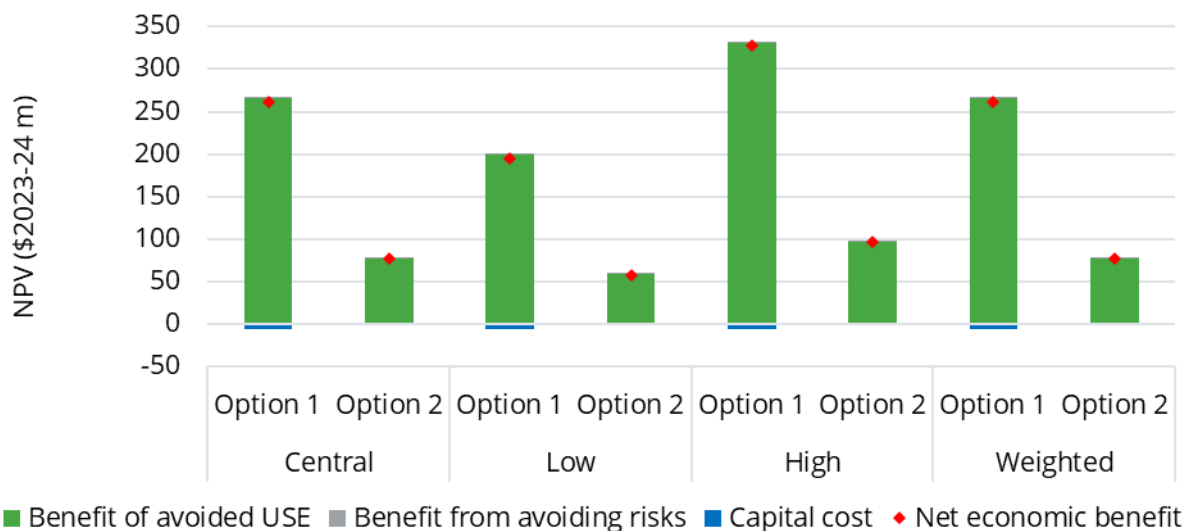

Option 1 has the greatest net market benefits under each scenario and the weighted scenario and is therefore our preferred option.

## 7.4 Sensitivity testing

We have undertaken sensitivity testing to examine how the net economic benefit of the credible options changes with respect to changes in key modelling assumptions. The factors tested as part of the sensitivity analysis for this PSCR are:

- Optimal timing of the project
- Alternate scenario weights
- Higher or lower VCRs
- Higher or lower network capital costs of the credible options
- Alternate commercial discount rate assumptions.

The sensitivity testing was undertaken as against the central scenario. Specifically, we individually varied each factor identified above and estimated the net economic benefit in that scenario relative to the base case while holding all other assumptions under the central scenario constant. The results of the sensitivity tests are set out in the sections below.

### 7.4.1 Optimal timing of the project

We have estimated the optimal timing for the preferred option. The optimal timing of an investment is the year when the annual benefits (avoided risk costs) from implementing the option become greater than the



annualised investment costs. The analysis was undertaken under the central set of assumptions and a range of alternative assumptions for key variables. The purpose of the analysis is to examine the sensitivity of the commissioning year to changes in the underlying assumptions.

The sensitivities we considered are:

- a 25% increase / decrease in capital costs
- a 25% increase / decrease in demand
- a lower discount rate of 3% and a higher discount rate of 10.5%
- a 30% increase / decrease in the VCR
- a 25% increase / decrease in reliability, safety, environmental and financial risk costs

The results of this analysis are presented in the figure below. In all cases, the optimal timing for the preferred option is 2025/26.

Figure 7-2 Distribution of optimal timing under a range of different key assumptions

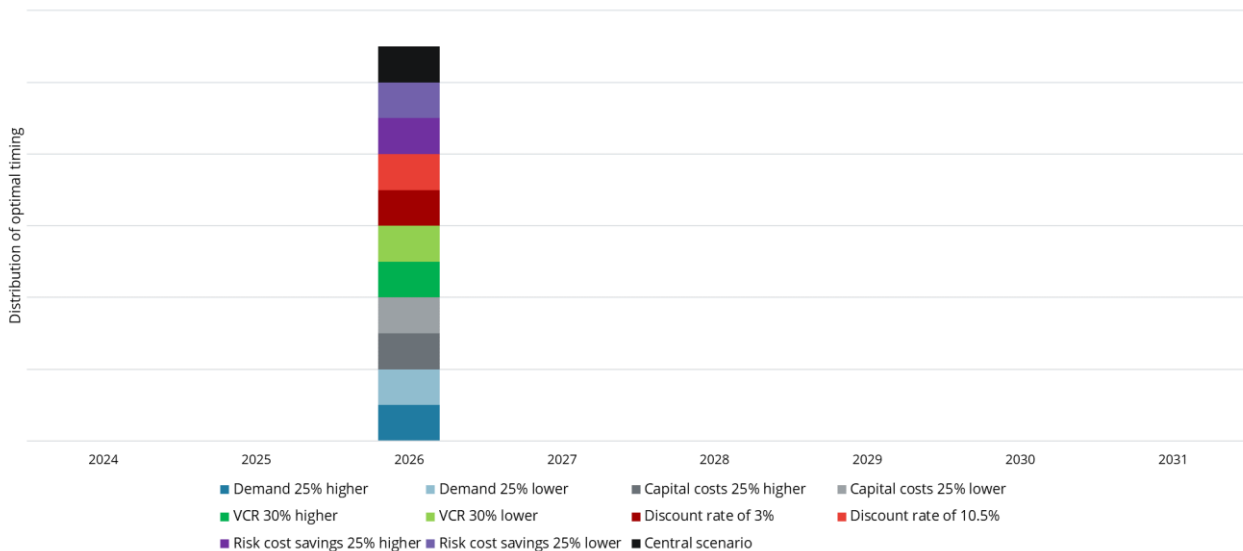

### 7.4.2 Scenario weights

There are no alternative scenario weights that will change the RIT-T outcome (i.e., lead to the identification of a different preferred option, or no preferred option).

### 7.4.3 Value of customer reliability

We estimated the net economic benefit of each option by adopting a VCR that is 30% higher (the 'High VCR' scenario) and 30% lower (the 'Low VCR' scenario) than the estimate of VCR adopted in our central scenario. The results of this analysis are presented in the table and figure below.

Table 7-4 Sensitivity of net economic benefits under a lower and higher VCR (\$2023/24 m)

Option/scenario	Low VCR	High VCR	Ranking
<i>Sensitivity</i>	<i>Central estimate - 30%</i>	<i>Central estimate + 30%</i>	
Option 1	181.66	340.77	1
Option 2	53.29	99.83	2

Figure 7-3 Sensitivity of net economic benefits under a lower and higher VCR (\$2023/24 m)

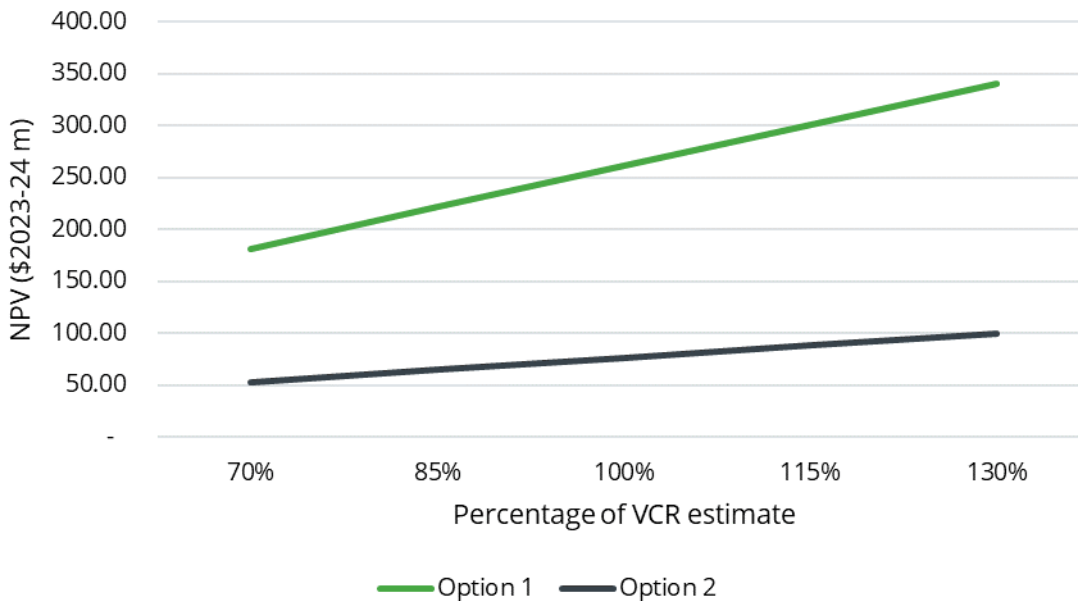

Option 1 remains the preferred option under both a low and high VCR scenario.

#### 7.4.4 Network capital costs

We estimated the net economic benefit of each option by adopting capital costs for each option that are 25% higher (the ‘High capex’ scenario) and 25% lower (the ‘Low capex’ scenario) than the capital cost estimates in our central scenario. The results of this analysis are presented in the table and figure below.

Table 7-5 Sensitivity of net economic benefits under lower and higher capital costs (\$2023/24 m)

Option/scenario	Low capex	High capex	Ranking
<i>Sensitivity</i>	<i>Central estimate - 25%</i>	<i>Central estimate + 25%</i>	
Option 1	262.76	259.67	1
Option 2	76.84	76.28	2

Figure 7-4 Sensitivity of net economic benefits under lower and higher capital costs (\$2023/24 m)

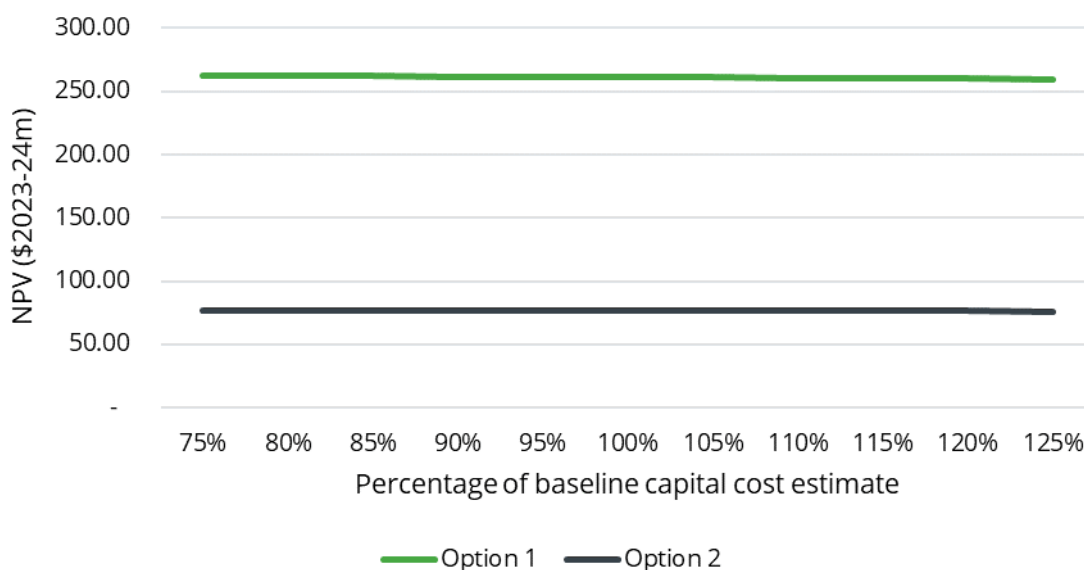

Option 1 remains the preferred option under both a low and high capital cost scenario.

We have also undertaken a threshold analysis to identify whether a change in capital cost estimates would change the RIT-T outcome. Specifically, we considered the level of increase in the capital costs of Option 1 to change the RIT-T outcome (i.e. the base case or Option 2 to be the preferred option). The result of this analysis was that the capital cost would need to increase by over 3,600% for the RIT-T outcome to change. Such a change in capital costs is outside the expected range of costs and, as such, this result of Option 1 being the preferred options is robust to reasonable capital cost sensitivities.

#### 7.4.5 Discount rate

We estimated the net economic benefit of each option by adopting a low discount rate of 3% which is consistent with the AER’s latest final determination for a TNSP (the ‘Low discount rate’ scenario),<sup>35</sup> and a high discount rate of 10.5% which aligns with the high discount rate scenario in the 2023 IASR (the ‘High discount rate’ scenario).<sup>36</sup> The results of this analysis are presented in the table and figure below.

Table 7-6 Sensitivity of net economic benefits under a lower and higher discount rates (\$2023/24 m)

Option/scenario	Low discount rate	High discount rate	Ranking
<i>Sensitivity</i>	3%	10.5%	
Option 1	384.31	170.75	1
Option 2	110.90	50.69	2

<sup>35</sup> This is equal to WACC (pre-tax, real) in the latest final decision for a transmission business in the NEM (Transgrid) as of the date of this analysis, see: <https://www.aer.gov.au/networks-pipelines/determinations-access-arrangements/transgrid-determination-2023%E2%80%9328/final-decision>

<sup>36</sup> AEMO ‘2023 Inputs, Assumptions and Scenarios Report’, July 2023, p 123.

Figure 7-5 Sensitivity of net economic benefits under a lower and higher discount rates (\$2023/24)

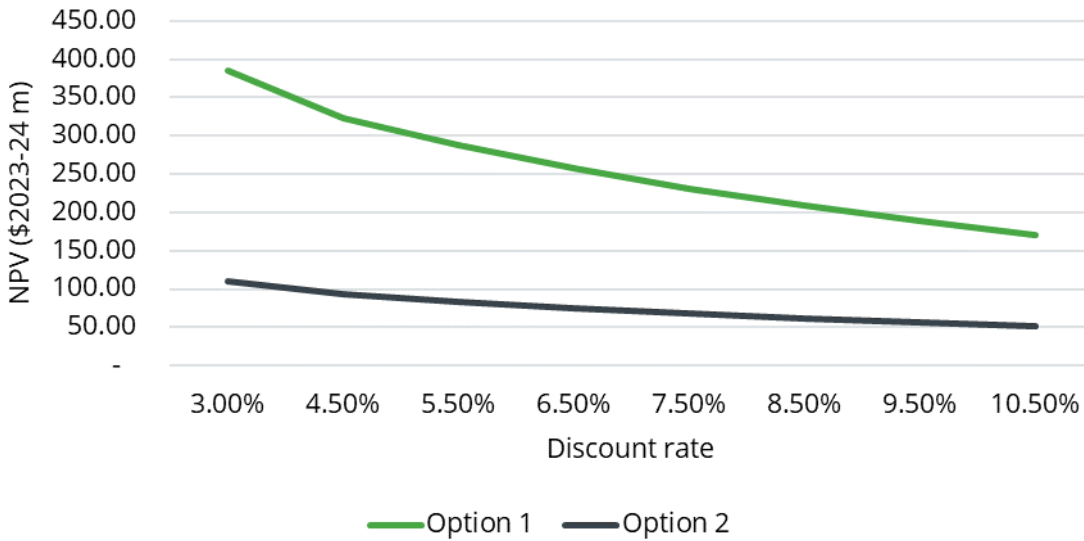

We have also undertaken a threshold analysis to identify whether a change in the discount rate would change the RIT-T outcome. Our approach involved solving for the discount rate that would result Option 1 not being the preferred option (i.e. the base case or Option 2 becoming the preferred option). Our results suggest that discount rate would need to be above 100% to change the RIT-T outcome. Such a change in discount rate is outside the expected range of rates and, as such, this result of Option 1 being the preferred options is robust to reasonable discount rate sensitivities.

## 8. Draft conclusion and exemption from preparing a PADR

---

This PSCR finds that Option 1 is the preferred option to address the identified need. Option 1 involves the replacement of the Molong No.1 transformer with a new 132/66 kV 30 MVA transformer. Implementation of Option 1 is expected to reduce the probability of failure of the power transformer at Molong substation. This will reduce the frequency and duration of involuntary load shedding associated with the failure of this asset. Option 1 will also reduce the risk of asset failure, which will in turn reduce associated environmental, safety and financial risk costs.

The capital cost of this option is approximately \$7.08 million (in \$2023/24). The work will be undertaken across a single year period with all works expected to be completed by the end of 2025/26. Routine operating and maintenance costs are estimated at approximately \$0.001 million per annum (in \$2023/24).

Subject to the identification of additional credible options during the consultation period, publication of a Project Assessment Draft Report (PADR) is not required for this RIT-T as we consider that the conditions in clause 5.16.4(z1) of the NER exempting RIT-T proponents from providing a PADR have been met.

Specifically, production of a PADR is not required because:

- the estimated capital cost of the preferred option is less than \$46 million;<sup>37</sup>
- we have identified in this PSCR our preferred option and the reasons for that option, and noted that we will be exempt from publishing the PADR for our preferred option; and
- we consider that the preferred option and any other credible options do not have a material market benefit (other than benefits associated with changes in voluntary load curtailment and involuntary load shedding).

If an additional credible option that could deliver a material market benefit is identified during the consultation period, then we will produce a PADR that includes an NPV assessment of the net economic benefit of each additional credible option.

If no additional credible options with material market benefits are identified during the consultation period, then the next step in this RIT-T will be the publication of a PACR that addresses all submissions received, including any issues in relation to the proposed preferred option raised during the consultation period.<sup>38</sup>

---

<sup>37</sup> Varied from \$43m to \$46m based on the [AER Final Determination: Cost threshold review](#), November 2021.

<sup>38</sup> In accordance with NER clause 5.16.4(z2).

## Appendix A Compliance checklist

This appendix sets out a checklist which demonstrates the compliance of this PSCR with the requirements of the National Electricity Rules version 208.

Rules clause	Summary of requirements	Relevant section
5.16.4 (b)	A RIT-T proponent must prepare a report (the project specification consultation report), which must include:	–
	(1) a description of the identified need;	2
	(2) the assumptions used in identifying the identified need (including, in the case of proposed reliability corrective action, why the RIT-T proponent considers reliability corrective action is necessary);	2
	(3) the technical characteristics of the identified need that a non-network option would be required to deliver, such as: <ul style="list-style-type: none"> <li>(i) the size of load reduction of additional supply;</li> <li>(ii) location; and</li> <li>(iii) operating profile;</li> </ul>	4
	(4) if applicable, reference to any discussion on the description of the identified need or the credible options in respect of that identified need in the most recent Integrated System Plan;	NA
	(5) a description of all credible options of which the RIT-T proponent is aware that address the identified need, which may include, without limitation, alternative transmission options, interconnectors, generation, system strength services, demand side management, market network services or other network options;	3
	(6) for each credible option identified in accordance with subparagraph (5), information about: <ul style="list-style-type: none"> <li>(i) the technical characteristics of the credible option;</li> <li>(ii) whether the credible option is reasonably likely to have a material inter-network impact;</li> <li>(iii) the classes of market benefits that the RIT-T proponent considers are likely not to be material in accordance with clause 5.15A.2(b)(6), together with reasons of why the RIT-T proponent considers that these classes of market benefits are not likely to be material;</li> <li>(iv) the estimated construction timetable and commissioning date; and</li> <li>(v) to the extent practicable, the total indicative capital and operating and maintenance costs.</li> </ul>	3 & 5

5.16.4(z1)	<p>A RIT-T proponent is exempt from [preparing a PADR] (paragraphs (j) to (s)) if:</p> <ol style="list-style-type: none"> <li>1. the estimated capital cost of the proposed preferred option is less than \$35 million<sup>39</sup> (as varied in accordance with a cost threshold determination);</li> <li>2. the relevant Network Service Provider has identified in its project specification consultation report: (i) its proposed preferred option; (ii) its reasons for the proposed preferred option; and (iii) that its RIT-T project has the benefit of this exemption;</li> <li>3. the RIT-T proponent considers, in accordance with clause 5.15A.2(b)(6), that the proposed preferred option and any other credible option in respect of the identified need will not have a material market benefit for the classes of market benefit specified in clause 5.15A.2(b)(4) except those classes specified in clauses 5.15A.2(b)(ii) and (iii), and has stated this in its project specification consultation report; and</li> <li>4. the RIT-T proponent forms the view that no submissions were received on the project specification consultation report which identified additional credible options that could deliver a material market benefit.</li> </ol>	8
------------	---	---

<sup>39</sup> Varied to \$46m based on the [AER Final Determination: Cost threshold review](#) November 2021.

## Appendix B Risk assessment framework

This appendix summarises our network risk assessment methodology that underpins the identified need for this RIT-T. Our risk assessment methodology is aligned with the AER’s Asset Replacement Planning guideline<sup>40</sup> and its Principles.

A fundamental part of the risk assessment methodology is calculating the annual ‘risk costs’ or the monetised impacts of the reliability, safety, bushfire, environmental and financial risks.

The monetary value of risk (per year) for an individual asset failure resulting in an undesired outcome, is the likelihood (probability) of failure (in that year with respect to its age), as determined through modelling the failure behaviour of an asset (Asset Health), multiplied by the consequence (cost of the impact) of the undesired outcome occurring, as determined through the consequence analysis (Asset Criticality). Figure B-1 illustrates the base risk equation that we apply.

Figure B-1 Risk cost calculation

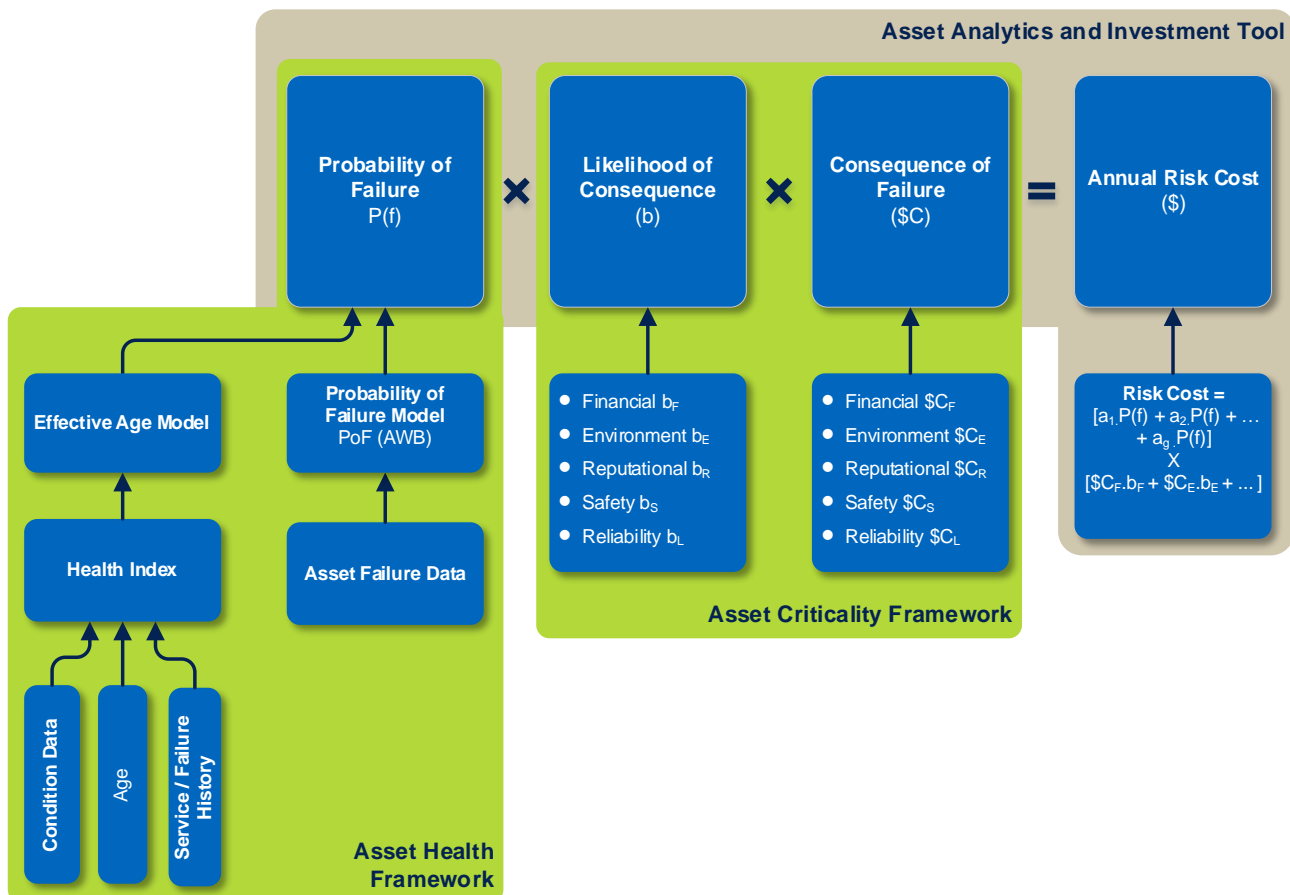

Economic justification of Repex to address an identified need is supported by risk monetised benefit streams, to allow the costs of the project or program to be assessed against the value of the avoided risks and costs. The major quantified risks we apply for Repex justifications include asset failures that materialise as:

<sup>40</sup> [Industry practice application note - Asset replacement planning, AER January 2019](#)



- Bushfire risk
- Safety risk
- Environmental risk
- Reliability risk, and
- Financial risk.

The risk categories relevant to this RIT-T are explained in Section 2.3.

Further details are available in our [Network Asset Risk Assessment Methodology](#).

## Appendix C Asset Health and Probability of Failure

The first step in calculating the probability of failure of an asset is determining the Asset Health and associated effective age,<sup>41</sup> which considers:

- An asset consists of different components, each with a particular function, criticality, underlying reliability, life expectancy and remaining life. The overall health of an asset is a compound function of all of these attributes.
- Key asset condition measures and failure data provides vital information on the current health of an asset. The 'Current effective age' is derived from asset information and condition data.
- The future health of an asset (health forecasting) is a function of its current health and any factors causing accelerated (or decelerated) degradation or 'age shifting' of one or more of its components. Such moderating factors can represent the cumulative effects arising from continual or discrete exposure to unusual internal, external stresses, overloads and faults.
- 'Future effective age' is derived by moderating 'current effective age' based on factors such as, external environment/influence, expected stress events and operating/loading condition.

The Probability of Failure (PoF) is the likelihood that an asset will fail during a given period resulting in a particular adverse event.

The outputs of the Probability of Failure (PoF) calculation are one or more probability of failure time series which provide a mapping between the effective age, discussed above, and the yearly probability of failure value for a given asset class. This analysis is performed by generating statistical failure curves, normally using Weibull analysis, to determine a PoF time series set for each asset that gives a probability of failure for each further year of asset life. This establishes how likely it is that the asset will fail over time.

The Weibull parameters which represent the probability of failure curve for key assets are summarised in the table below.

Asset	Weibull parameters	
	$\eta$	$\beta$
Transformer	54.21	3.61
Oil Reactor	38.84	2.95
Circuit Breaker	47.76	4.3
Oil filled Current Transformer	50	3.08
Magnetic Voltage Transformer	50	3.8
Capacitive Voltage Transformer	50	3.8
Disconnecter	67	4.8
Surge Arrester	55	3.2
Auxillary Transformer	70	4.5
Capacitor bank	50	4.5
Multifunction Intelligent Electronic Device:	14.3	1.78

<sup>41</sup> Apparent age of an asset based on its condition.

- Protection - Controller - Telecommunication		
Protection Relay - Solid State	32.7	1.24
Protection Relay - Electromechanical	92.9	1.57
Protection Relay - Intertrip	26.2	1.54
Remote Terminal Unit	22.5	1.77
PC	12.7	2.09
Meter - Microprocessor	15.5	1.74
DC Battery	16.5	1.49
DC Charger	19.8	1.24