

Safe Work Practices on High Voltage Cables

Summary

This document supports the Power System Safety Rules and its requirements detailed under 'High Voltage Transmission Cables' Category 7.

It covers safe work practices on High Voltage Cables and Pilot Cables to ensure the safety of workers where it is possible for induced voltages and transfer of earth potentials to occur.

It also sets down the method of identifying cables and requirements for safeguarding cables when working on associated oil or gas systems.

Document Control

Revision no:	2	HP TRIM no:	D2005/01698	Approval/ Review date:	11/03/2020
Business function:	Manage Health And Safety			Document type:	Corporate Work Instruction
Process owner:	Head/Health, Safety and Environment				
Related Procedure/s:	Power System Safety Rules				
Author:	Kitchener Morris, PSSR Manager				
Reviewers:	Megan Calvert, HSE Systems Manager Mark Dorahy, Cables Officer Chris Kezik, Delivery Manager James Mason, Training Designer				
Approver:	Michael Gatt, EM, Works Delivery				

Warning: A printed copy of this document may not be the current version. Please refer to the Wire to verify the current version.

Contents

1. Purpose	4
2. Scope	4
2.1 Document Location	4
3. Definitions	5
4. Work on HV Cables - General	5
4.1 Work with HV Transmission Cables in Service	5
4.2 Work with HV Transmission Cables Isolated Only	5
4.2.1 Types of Work requiring a cable isolated	5
4.2.2 Access procedure for work related to an isolated only cable	5
4.3 Work with HV Cables Isolated and Earthed	6
4.4 Work on HV Transmission Cables as Disconnected Apparatus	6
5. HV Transmission Cable Hazardous Situations	7
6. Basic Principles for Determining Safe Working Methods	8
6.1 Bonded Earth Conditions	8
6.2 Insulated Working Conditions	9
6.3 Safe Work Methods	10
7. Identification of HV Cables and Pilot Cables	12
7.1 General	12
7.1.1 HV Transmission Cables	12
7.1.2 Pilot Cables	12
7.2 High Voltage Cable Identification	12
7.3 Pilot Cable Identification	12
7.4 Precautions	13
8. Routine Maintenance	13
8.1 Sheath Repairs	13
8.2 Work on Link Boxes	13
8.3 Work on Oil System Equipment	14
8.4 Work on Cable Pressure Monitoring Equipment	14
8.5 Use of Instruments and Testing Equipment	14
9. Non-Routine Maintenance	14
9.1 Cutting a Cable	14
9.1.1 Cutting a HV Cable or Pilot Cable	14
9.2 Making a Joint in a Cable	14
9.2.1 Making a Joint in a Pilot Cable	15
9.3 Breaking Down a Joint in a HV Cable	16
9.4 Constructing a Sealing End on a HV Cable	16
9.5 Breaking down a Sealing End in a HV Cable	19
9.6 Terminating a Pilot Cable	19

Warning: A printed copy of this document may not be the current version. Please refer to the Wire to verify the current version.

9.6.1	Terminating in Pilot Isolation Kiosks.....	19
9.6.2	Terminating at Locations other than in Isolation Kiosk (including Cable Road Pits).....	20
9.7	Metallic Part Repairs of HV Cables or Pilot Cables	20
9.7.1	Metallic Part Repairs Utilising Insulated Working Conditions	20
9.7.2	Metallic Part Repairs Utilising Bonded Earth Mat Conditions	21
10.	Installation of HV Cables and Pilot Cables	21
10.1	General	21
10.2	Advice to Controller	21
10.3	Positioning of Oil Plants and Other Equipment.....	21
10.4	Pulling of HV Cables and Pilot Cables	22
10.4.1	Cable Pulling Requirements	22
10.4.2	First Joint Bay-Insulation of Cable Metallic Parts.....	23
10.4.3	Cable Sealing Ends – Working Methods.....	23
10.4.4	Cable Sealing Ends – Isolation from Substation Earth	23
10.4.5	Field Jointing.....	23
10.5	Pilot Cable Terminations and Jointing.....	23
11.	Accountability.....	23
12.	Implementation	24
13.	Monitoring and Review	24
14.	Change from previous version	24
15.	Reference Documents	25
16.	Attachments.....	25

Warning: A printed copy of this document may not be the current version. Please refer to the Wire to verify the current version.

1. Purpose

This document supports the Power System Safety Rules and its requirements assembled under 'High Voltage Transmission Cables' Category 7. The document describes safe working practices on High Voltage (HV) cables and pilot cables.

2. Scope

This document applies to all persons working on HV cables and pilot cables.

It covers safe work practices on High Voltage Cables and Pilot Cables to ensure the safety of workers where it is possible for induced voltages and transfer of earth potentials to occur. It also sets down the method of identifying cables and requirements for safeguarding cables when working on associated oil systems.

This is in addition to the requirements of any Legislation, Codes of Practice or Guidelines, as applicable.

2.1 Document Location

The following diagram shows the relationship between this and other relevant PSSR procedures.

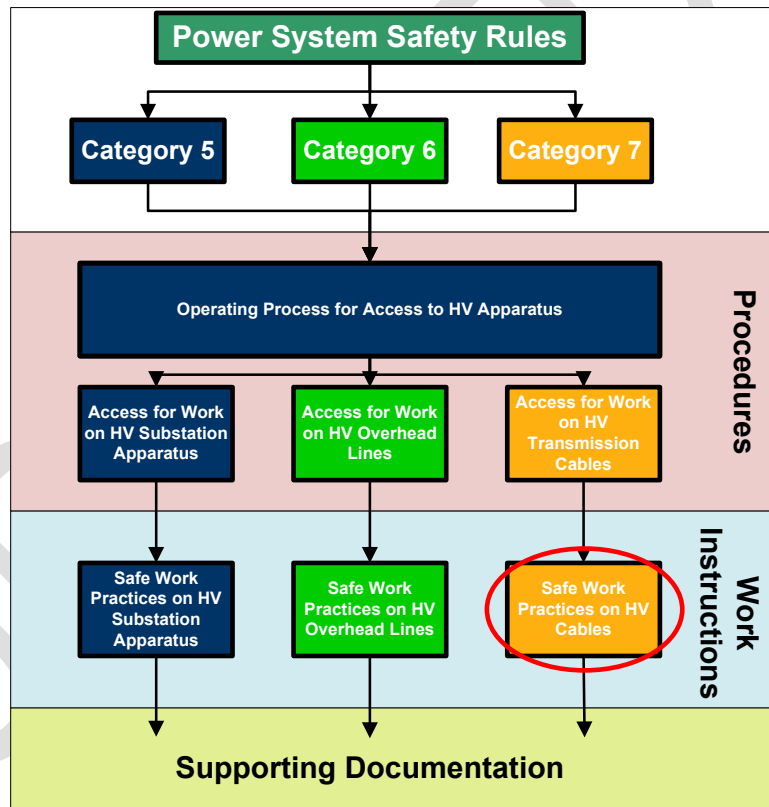

Warning: A printed copy of this document may not be the current version. Please refer to the Wire to verify the current version.

3. Definitions

Term	Definition
17kV ac	Means a voltage of 17kV ac applied for a one minute test
Metallic Part	The metallic part of a cable is the armour, metallic sheath, reinforcing tapes, metallic screen and cores, or any metallic part connected to one of these.
HV Transmission Cable	HV Cable 22kV and above interconnecting two substations.

4. Work on HV Cables - General

For all work associated with HV Cables, in the charge of a controller, an RFA shall be submitted in accordance with Section 2 of the Power System Safety Rules.

4.1 Work with HV Transmission Cables in Service

Certain work may be carried out with a cable in service and without the issue of a Cable Access Authority. The work allowable and the applicable conditions are set down in 7.1.3 of the PSSR.

4.2 Work with HV Transmission Cables Isolated Only

4.2.1 Types of Work requiring a cable isolated

Although work is permitted with a cable in service under Rule 7.1.3, the practicalities of certain types of work mean that it will be necessary to have the cable isolated. The types of work in this category are:

- Work on oil panels and external pipe work if there is risk of causing oil to drain from the cable. Pipe work is insulated from metallic parts of a cable installation, but loss of oil affects the integrity of the cable insulation.
- Connection and reading of pressure gauges along a cable route. This will be required during work to find the location of oil leaks. Pressure readings are more accurate when the cable is in a stable thermal condition, which is best achieved with the cable off load.
- With oil filled cables it is preferred that the cable be isolated even for slight movements, even though this is not specifically required by the PSSR.
- When there is interference with a cable trench (e.g. excavation works) there might be a fault on or obvious damage to one cable and the suspicion of damage to another cable in the same trench. Whilst work is being carried out on the faulty cable the suspect cable should be isolated.
- Where it is required to manage induced currents and voltages.

4.2.2 Access procedure for work related to an isolated only cable

Work requiring a HV Transmission Cable to be isolated will be performed under a LV/MECH Access Authority in accordance with the following procedure.

- Requests for Access with the cable isolated shall be made on a Request to Access form with LV/MECH specified in "Access Required" column. Recall arrangements must be made during the outage assessment process to ensure workers will be available to effect the recall. To enable recall, workers on site are to remain in close contact with the Controller during the outage.
- The isolation of the cable and the clearance to issue the LV/MECH Access Authority shall be managed by the Controller through a HVPRI.

Warning: A printed copy of this document may not be the current version. Please refer to the Wire to verify the current version.

- (c) On completion of the day's work the cable maintenance worker holding the LV/MECH Access Authority is to suspend or cancel the LV/MECH Access Authority as per the requirements in the Access for Work on LV/MECH Apparatus procedure.

4.3 Work with HV Cables Isolated and Earthed

HV Cable work that requires the cable be made safe for work shall have an Access Authority issued in accordance with TransGrid's 'Power System Safety Rules' and 'Access for Work on HV Transmission Cables'. A summary is set out below:

- > A HV Access Authority (HV Substation Cables);
- > A HV Testing Access Authority (Testing HV Substation Cables);
- > A Cable Access Authority (HV Transmission Cables); and
- > A Cable Testing Access Authority (Testing HV Transmission Cables).

Concurrent Access Authorities may be issued on the one cable provided the Controller is satisfied that adequate isolation can be achieved between any section of metallic sheath to be tested and all apparatus being worked on by other parties. This will allow:

- > Concurrent high voltage testing on different sections of sheath on the same cable;
- > Concurrent high voltage testing on sections of the cable sheath and work on the main conductor of the cable. (Cable dielectric provides sufficient insulation to allow testing voltages to be applied to the cable sheath while workers are working on the isolated and earthed primary conductor); and
- > Concurrent high voltage testing, in the field, of a section of insulated metallic cable sheath and work in terminating switchyards.

4.4 Work on HV Transmission Cables as Disconnected Apparatus

If a long outage of HV transmission cables is proposed it may be possible to disconnect it temporarily from the system prior to working on it without an Access Authority. In such a case, the PSSR requirements for 'Making Disconnected HV Cables Safe for Work' Rule 7.5.5 and the document 'Work on Disconnected Apparatus' Section 5 must be complied with.

5. HV Transmission Cable Hazardous Situations

The following table lists typical situations encountered when working on or in the vicinity of HV transmission cables and the controls to be implemented.

Situation	Hazards	Controls	Reference
Excavation of underground cables	Buried Services	An excavation permit or equivalent document outside a substation; A cable access authority (unless specifically precluded under rule 7.1.3)	Excavation Permit WorkCover Guide 'Work Near Underground Assets' 2007
Working in the vicinity of a cable sealing end	Exposed HV conductors	Safe approach distances shall be maintained for persons and plant	PSSR – Attachment B
Removal of Earth Connections	Dangerous Voltages	Earth connections between cable sheaths and the earthing system shall not be removed while the cable is in service.	PSSR 7.1.1
Cable testing	Capacitance	Equipment shall be fully discharged before working on the apparatus after electrical testing has been performed.	PSSR 7.4.1
Identifying HV Cables and Pilot Cables	Incorrect identification of Cables.	Work must not commence on HV Cables and Pilot Cables or accessories until the equipment which it is safe to work on has been positively identified.	This document Section 7
Cable maintenance	Dangerous Voltages	Bonded earth mat or Insulated working conditions established depending on work	This document Sections 8 and 9
Installation of HV Cables and Pilot Cables	Switchyard Earth Grid Voltage Rise & Transferred Earth Potentials	Equipment that may be subject to transferred earth potentials shall be either insulated, isolated, or otherwise rendered safe.	This document Section 10

Warning: A printed copy of this document may not be the current version. Please refer to the Wire to verify the current version.

6. Basic Principles for Determining Safe Working Methods

It is essential when developing safe working procedures to carefully assess the possibility of hazardous voltage rises occurring at the work site and where appropriate, give consideration to the following basic safe working principles:-

- (a) When working on a HV cable conductor (including a metallic sheath, armouring, oil line, etc., which can be subject to dangerous voltage rise, 'bonded earth mat working conditions' should preferably be employed. Where this is not possible, 'insulated working conditions' must be adopted.

Note: Due to the practical difficulties in maintaining insulated working conditions in field situations, use of this method should be limited to only those times where bonded earth mat working conditions are not able to be used.

- (b) Remote earths should not be introduced to the local work site earth mat situation where practical. Therefore, where the PSSRs allow it, all remote earths connected to the conductors being worked on need to be disconnected. Also precautions need to be taken to isolate all incoming electric leads (e.g. for lighting and power tools) connected to a remote earth by the use of an isolating transformer. Also any oil equipment etc., must be isolated by use of insulating hoses or connectors.
- (c) Conductors being worked on should be kept as short as possible by disconnecting phase conductors and/or cable sheath sectionalisation.
- (d) The maximum number of continuous and earthed parallel conductors should be maintained at all times to maximise the shielding effect. See Appendix F for further information

6.1 Bonded Earth Conditions

Bonded earth conditions comprise an equipotential area made from conductive material, such as 25mm galvanised wire mesh. The conductive material shall be continuously bonded with multiple bonds and shall cover the floor, walls and ceilings, as necessitated by the conditions of any areas which can be touched from the working position. An earth stake shall be driven to a minimum depth of 600mm at each end of the working area and the two stakes bonded together or, alternatively, a single earth stake may be driven and used in conjunction with the existing earthing system of the cable installation.

Side driving of an earth stake is acceptable at locations that are at least 600mm below the surface.

Regardless of the earthing arrangement used, the overall resistance between the equipotential conductors and the surrounding earth must be less than 10 Ohms.

WARNING: Extreme care must be taken when driving earth stakes to ensure no damage is caused to the cable or to other services.

All earth connections from the bonded earth mat or from other exposed metalwork shall be made effectively and solidly to the earth stake with a conductor of minimum size 16mm² or equivalent. All exposed and lightly insulated metal objects within the equipotential area shall be bonded to the earth stake or covered with a material insulated to withstand 17kV ac.

A barrier to prevent persons contacting the bonded earth mat shall be erected at least one metre from the edges of the working area or associated metallic tent frame. Where this cannot be achieved, this distance may be reduced at the discretion of the authorised person issuing the Cable Access Authority and or the APIC for the Cable Access Authority, subject to other control measures being implemented.

Access to the bonded earth mat shall be made via a non-conductive ladder or staircase and an insulated platform or mat suitable to control step potential effects. Refer to figure below.

Warning: A printed copy of this document may not be the current version. Please refer to the Wire to verify the current version.

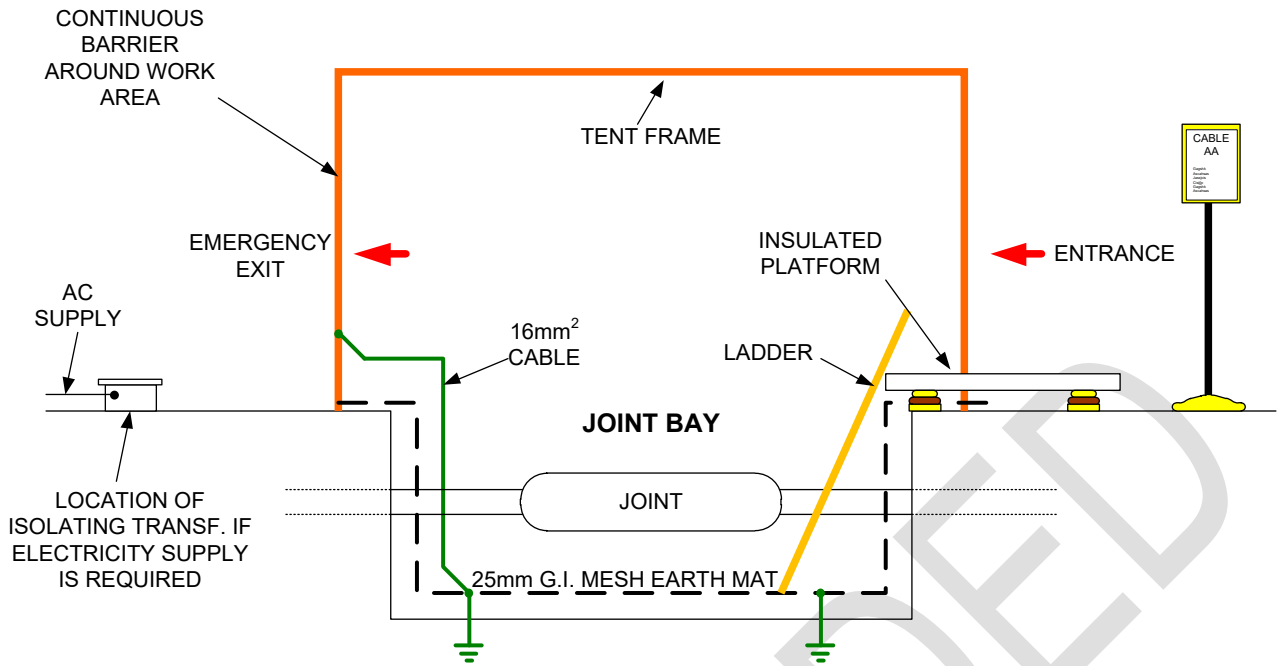

Figure 1: Typical arrangement of bonded earth connections for a joint bay

6.2 Insulated Working Conditions

Insulated working conditions means that an insulated platform shall be used within the work zone, and all insulated parts shall be kept as clean and dry as possible. All exposed metallic parts of cables and pipes or any other earthed material which can be touched from the insulated platform whilst in contact with the unearthed metallic parts of the cable to be worked on, shall be covered with a material, insulated to withstand 17kV ac, which shall be maintained in as clean and dry a condition as possible. All connections to the earth stake shall be made with a conductor of minimum size 16mm² or equivalent, insulated to withstand 17kV ac. Refer to figure below.

Any person on the insulated platform must not accept materials from or make personal contact with any person not on the platform or touch any earthed object while in contact with the unearthed metallic parts of the cable.

A barrier to prevent unauthorised entry shall be erected at least one metre from the edges of the working area. Where this cannot be achieved, this distance may be reduced at the discretion of the authorised person issuing the Cable Access Authority or the Authorised Person In Charge of the Cable Access Authority, subject to other control measures being implemented.

Warning: A printed copy of this document may not be the current version. Please refer to the Wire to verify the current version.

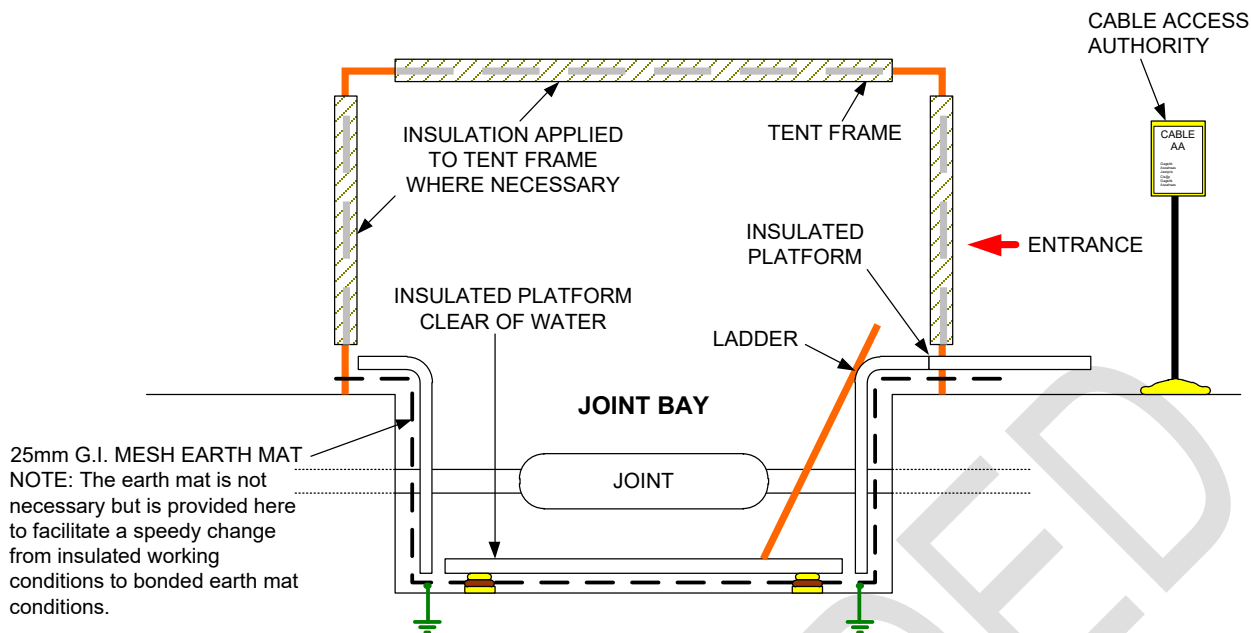

Typical Arrangement of Insulated Work Conditions for a Joint Bay

Figure 2: Insulated Working Conditions Arrangement

6.3 Safe Work Methods

The following figures illustrate the safe working methods to be used when effecting repairs on a cable.

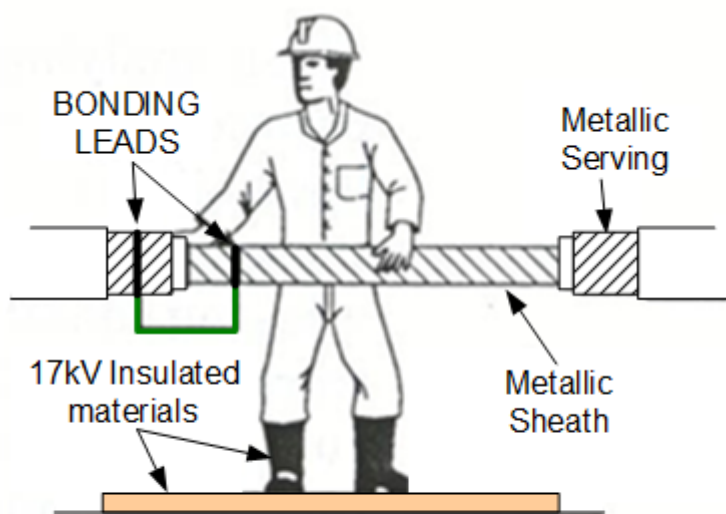

Working Method for effecting Repairs on Reinforcing tapes

Figure 3: Insulated Working

Warning: A printed copy of this document may not be the current version. Please refer to the Wire to verify the current version.

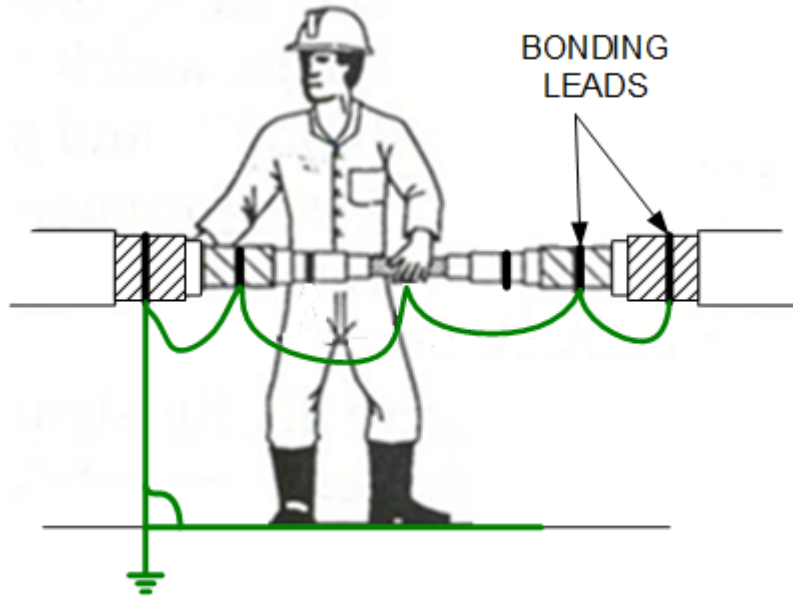

Working Method for effecting Repairs on Cable Core

Figure 4: Fully Bonded (Preferred)

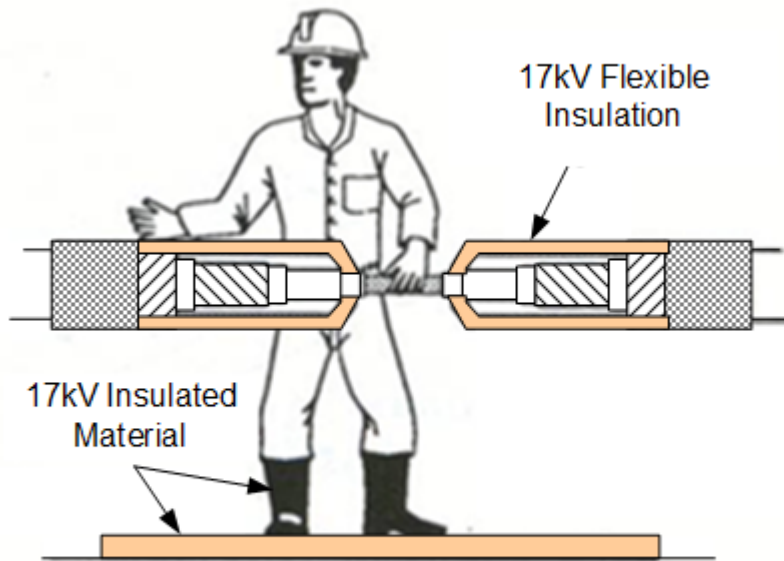

Working Method for effecting Repairs on Cable Core

Figure 5: Insulated working

Warning: A printed copy of this document may not be the current version. Please refer to the Wire to verify the current version.

7. Identification of HV Cables and Pilot Cables

7.1 General

The location of TransGrid's HV cables shall be identified using TransGrid's cable routing records. The location of other utilities services is available through Dial Before You Dig 1100 or www.1100.com.au.

Where the location of previously installed cables is discovered to be inaccurately recorded, the records shall be updated. Where existing cables are de-commissioned, but left in situ, the records, including Dial Before You Dig and spatial information shall be maintained until the cables are removed.

Cable identification involving injection of a signal into the cable sheath shall be via induction coupling.

Tests shall be carried out to correctly identify a cable prior to any work, except in the following cases:

7.1.1 HV Transmission Cables

- (a) Work permitted by the PSSR 7.1.3 with the cable in service.
- (b) Work on cable terminations in high voltage switchyards where the terminations have been isolated, proved de-energised and earthed in accordance with the PSSR.

7.1.2 Pilot Cables

- (a) Where pilot cores are not exposed or will not become exposed as a result of the repairs.
- (b) Movement of the cable which does not involve excessive bending or mechanical stress.

7.2 High Voltage Cable Identification

The issuer and receiver of the Access Authority carrying out the identification shall employ at least two of the following methods, or alternatively, repeat method (a) or (b) from a different location or, using different personnel, from the same location.

- (a) Identification by Plans
By identification from cable route plans, provided route plans are considered a true record.
- (b) Local labelling of ancillary equipment directly connected to the cable.
- (c) Low voltage audio frequency current injection at the end of the cable
Injection of an audio frequency current into the core and detection of the current at the worksite by an electro-magnetically coupled search coil and amplifier.
- (d) Low voltage 50Hz current injection at the end of the cable or bond system from a known/labelled sheath link box.
Injection of an interrupted 50Hz current into the core and measurement of the current at the worksite with a tong ammeter or similar device and trigger/interruption pulses identified.
- (e) D.C. Simulated Sheath Fault Location Test
Detection of an interrupted sheath earth fault connected at the point of work.
- (f) Visual Identification
By visually tracing the cable back to its source or bonding leads to link pits which have been correctly identified as in (a) or (b).
- (g) GPS coordinates and where true and accurate survey data exists and no other similar services are in the vicinity.

7.3 Pilot Cable Identification

The issuer and receiver of the Access Authority carrying out the identification shall employ one or more of the following methods.

- (a) Identification by Plans
By identification from cable route plans, provided route plans are considered a true record.

Warning: A printed copy of this document may not be the current version. Please refer to the Wire to verify the current version.

- (b) Visual Identification
By visually tracing the cable back to its source.
- (c) Identification by Labels
By identification from labels at pilot cable marshalling kiosks.
- (d) Low voltage audio frequency current injection at the end of the cables
Injection of an audio frequency current into a core or into the insulated metallic screen and detection of the current at the work site by an electromagnetically coupled search coil and amplifier.
- (e) Low voltage 50Hz current injection at the end of the cable
Injection of an interrupted 50Hz current into a core or into the insulated metallic screen and measurement of the current at the work site with tong ammeter or similar device.
- (f) D.C. simulated screen fault location test
Detection of an interrupted insulated metallic screen earth fault connected at the point of work.
- (g) Core continuity
By establishing continuity of an exposed core end at a break in the pilot cable to an identified termination position by injection of a continuous a.c. or d.c. current by megger or similar device, provided such method does not affect system security.

7.4 Precautions

Whatever method is used, the authorised person carrying out the identification shall affect self-protection, and protection for others from possible dangerous voltages that can occur during a system surge, by the following means:

- (a) At cable terminations in high voltage switchyards no connection or disconnection is to be made to any metallic part of a cable unless a local earth is first applied to the metallic part or unless the work is to be carried out under insulated working conditions.
- (b) In the field, insulated working conditions must be used to make connections to any metallic part of any HV cable or pilot cable.
- (c) Whilst operating the testing equipment, the qualified person shall employ insulated working conditions.
- (d) Where possible, all metallic parts of a HV cable not being used in the identification procedures shall be left continuous and earthed at both ends.

8. Routine Maintenance

A work method statement shall be produced and approved prior to conducting cable routine maintenance. The work method statement shall utilise the safe working practices in the following sections.

8.1 Sheath Repairs

Insulated working conditions shall be established and maintained until at least 3mm radial thickness of insulation has been applied over exposed metallic parts.

8.2 Work on Link Boxes

All work on link boxes must be carried out either:

- (a) With all links and terminals bonded and earthed in accordance with bonded earth conditions; or
- (b) Under insulated working conditions; or
- (c) Where it is necessary to remove links for identification or testing purposes, an approved type of insulated working must be used.

Warning: A printed copy of this document may not be the current version. Please refer to the Wire to verify the current version.

8.3 Work on Oil System Equipment

- (a) Where work is required between the insulating section in the metallic pipes and associated joint or sealing end the work shall be treated as a metallic part repair.
- (b) Any temporary feed pipe must be insulated from the metallic parts.
- (c) Any work on cable oil systems requiring the cable out of service for safety of equipment shall not be commenced until clearance has been received from the Controller and the requirements of section 4.2.2 have been met.

8.4 Work on Cable Pressure Monitoring Equipment

Cable “low oil” alarm equipment in the field is usually shrouded to prevent accidental contact with metallic parts that can be livened up due to induction or transferred earth potential.

When it is necessary to work on such metallic parts (for example on the contact assembly of a pressure gauge) insulated working conditions should be established.

Bonded earth conditions may be used provided the user ensures that the earthing of pilot cores is not harmful to the alarm system.

Caution is also required to ensure that personal contact is not made with more than one core at a time with the exception of where cores are commoned.

8.5 Use of Instruments and Testing Equipment

Instruments and Testing Equipment must conform to the requirements specified in Appendix C.

9. Non-Routine Maintenance

A work method statement shall be produced and approved prior to conducting cable non-routine maintenance. This work method shall take into account any cable type and manufacturer specific requirements for the equipment to be worked on. The work method statement shall, where possible, relevant and practical, utilise the safe working practices in the following sections.

9.1 Cutting a Cable

9.1.1 Cutting a HV Cable or Pilot Cable

The following steps are to be followed if a HV cable needs to be cut.

- (a) Identify the cable
- (b) Set up an exclusion zone around the cable to be cut
- (c) If necessary, use a remote detonation earth spike
- (d) Setup a remote operated cutter/guillotine and bond cutting head with a 16mm² cable to local earth/stake.
- (e) Bond all metallic parts of each end locally with 16mm² cable. If this is not practical, bridge all metallic parts across the cut with 16mm² cable. Alternatively (or in conjunction) apply 17kV insulated capping.
- (f) Contain any oil loss

9.2 Making a Joint in a Cable

Cable jointing is a highly specialised activity and the safe work methods and controls will vary depending on the cable type and manufacturer. Type and manufacturer specific techniques, hazards and controls must be considered when the safe work method for the work is being developed.

An example of jointing techniques and safety controls is provided in Appendix G.

Warning: A printed copy of this document may not be the current version. Please refer to the Wire to verify the current version.

9.2.1 Making a Joint in a Pilot Cable

(a) Initial Preparation

- i) Prepare the cable ends as outlined in Section 6.1.2 (a) to (g). Great care must be taken to ensure that bonding is completed, as shown in the following figure, by connection to the earthing board i.e., not by direct connections.

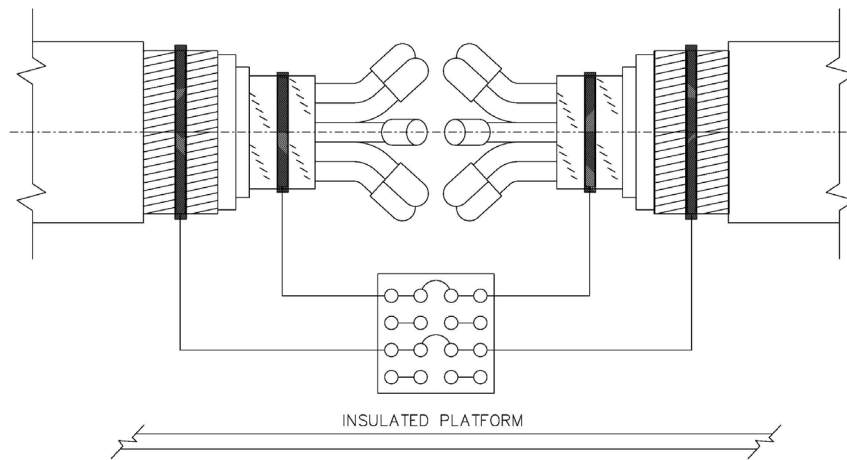

PILOT CABLE WITH METALLIC PARTS BONDED TO EARTH

Figure 6: Pilot Cable Bonding

- ii) Continue with insulated working conditions.
 - iii) Select the first pair to be joined and remove the temporary insulation. Slip on a core insulating sleeve and/or an insulated sleeve of material which will withstand 17kV ac.
 - iv) Handling one core end by the insulated sleeve and the other core end with its own insulation, lay down the core ends and mark the core joint positions.
- (b) Ferruled Core Joints
- i) Cut and strip the core end and crimp a ferrule on the core end, avoiding contact with the other core end.
 - ii) Handling one core end with insulated sleeve and the other core end with its own insulation, bring the two core ends together in the ferrule and complete crimping or sweating of the ferrule.
 - iii) Bring the core insulation sleeve over the core joint before proceeding with the next core joint.
- (c) Twisted Core Joints
- i) Bare the sections of cores only where the twist is to be made and complete at least one metal-to-metal turn without bridging the conductors by hand. The bare conductors are then safe to handle to complete the joint.
 - ii) Bring the core insulation sleeve over the core joint before proceeding with the next core joint.
- (d) Completion of Joints
- i) Remove the temporary insulating material from the innermost metallic part.
 - ii) Complete the continuity of this metallic part.
 - iii) Remove the bond on the innermost metallic part and apply insulation.
 - iv) Repeat steps (a) to (c) above for other metallic parts.

Warning: A printed copy of this document may not be the current version. Please refer to the Wire to verify the current version.

9.3 Breaking Down a Joint in a HV Cable

- (a) Utilising insulated working conditions expose a section of the outermost metallic part on either side of the joint.
- (b) Using bonding leads and an earthing board make a connection between the exposed metallic parts and an earth stake. Refer to figure below.

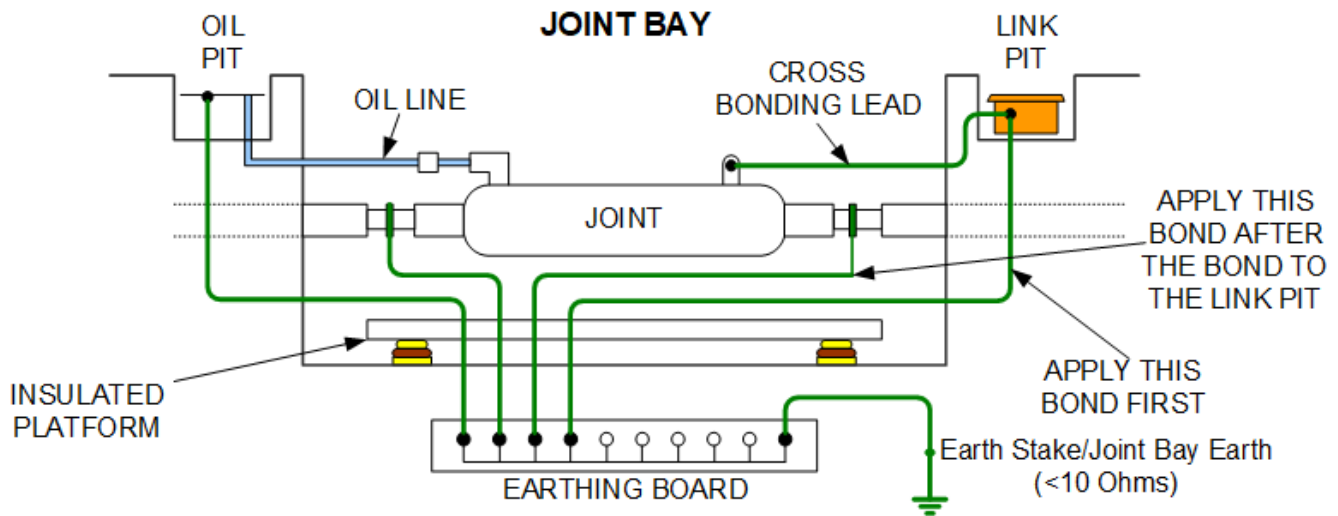

Bonding Leads applied to either side of a Cable Joint

Figure 7: Joint Bay Earthing

- (c) If oil lines and/or bonding leads are connected to the joint in question, then these lines and/or leads must also be connected to the earth stake. If these connections cannot easily be made near the joint, then they may be made in the adjacent oil, gas or link pits.
- (d) Establish bonded earth conditions.
- (e) Expose the joint sleeve (this usually involves de-compounding).
- (f) Disconnect oil pipes and bonding leads if required.
- (g) Remove joint sleeve.
- (h) Remove screen and stress wire if required.
- (i) Re-establish insulated working conditions.
- (j) Remove insulation.
- (k) If cutting of the conductor is contemplated the provisions of Section 9.1 apply.

Note: Items (g) – (k) may vary depending on the cable type and manufacturer. Specific requirements shall be detailed in the work method developed for the work.

9.4 Constructing a Sealing End on a HV Cable

- (a) The sealing end supporting structure and working platform scaffolding shall be effectively earthed to the local earth mat or earth stake as shown below.

Warning: A printed copy of this document may not be the current version. Please refer to the Wire to verify the current version.

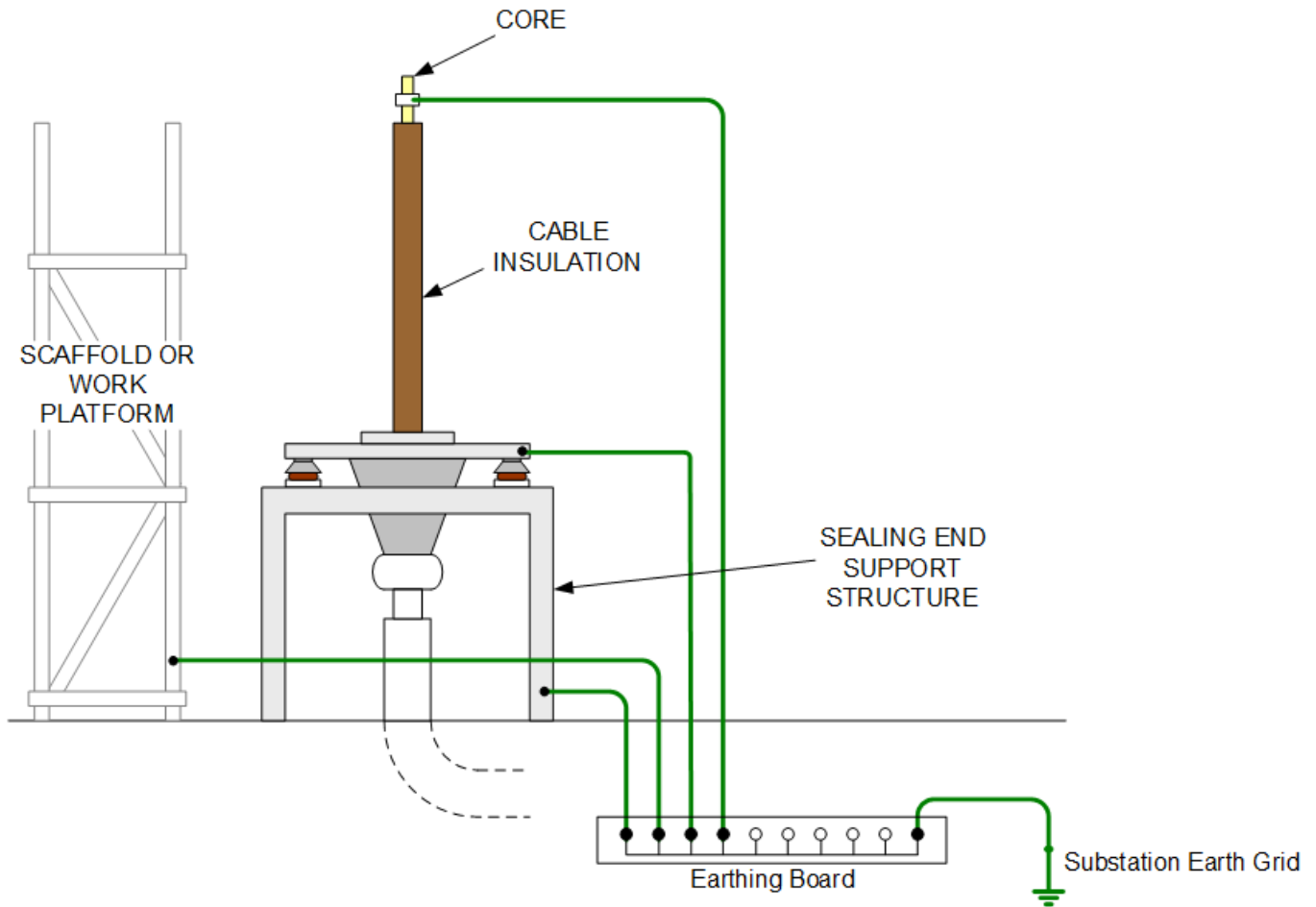

Earths applied to either side of a Cable Sealing End

Figure 8: Cable sealing end earthing

- (b) Prepare the cable
- (c) Continue with bonded earth conditions.
- (d) The earth bonds to all metallic parts must be maintained throughout all trimming, taping and screening operations until the bushing is in position ready to be lowered over the cable head.
- (e) Before removing the original core earths a bonding lead connection shall be made to the core passing up through the bushing as shown in the following figure.

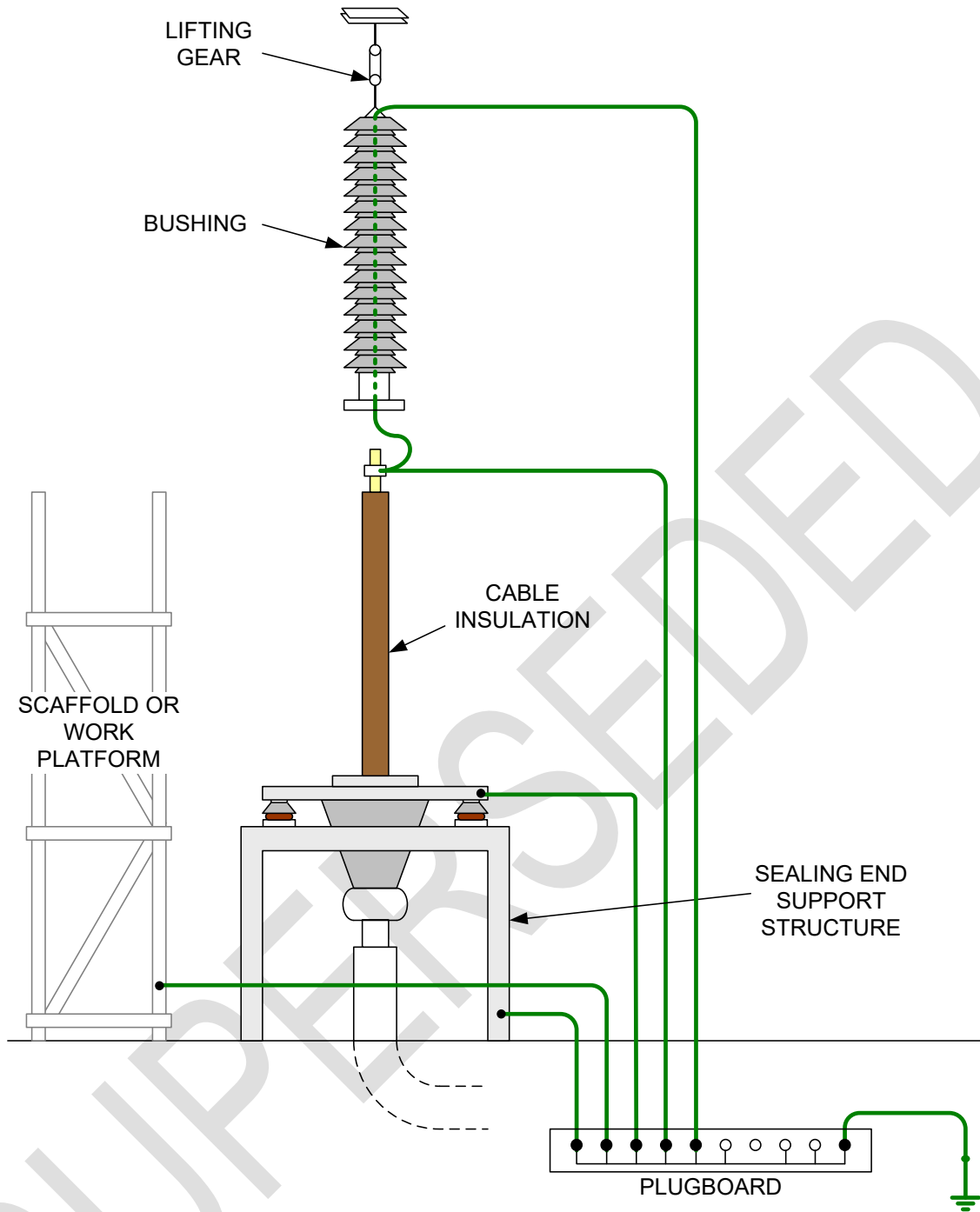

Bonding Lead applied to either side of a Cable Sealing End

Figure 9: Cable Sealing End Bushing Installation

The bonding lead is to be maintained until electrical contact is made with the top bushing fitting and this fitting is solidly earthed.

The core earth must not be disconnected until standard earthing equipment has been applied.

- (f) If it is impossible to comply with step (e) because of the design of the sealing end, the sealing end earth may be removed and the bushing lowered into position using insulated working conditions. The earth must be replaced as soon as possible and the remainder of the work carried out under bonded earth mat conditions.

Warning: A printed copy of this document may not be the current version. Please refer to the Wire to verify the current version.

9.5 Breaking down a Sealing End in a HV Cable

- (a) If the sealing end has not already been earthed by operating workers, make a connection between the primary conductor of the sealing end and the earth. Insulated working conditions must be used during this operation.
- (b) Continue with insulated working conditions and ensure that there is a connection between the metallic cable sheath and earth.
- (c) If oil lines and/or bonding leads are connected to the sealing end, then these lines and/or leads must also be connected to earth.
- (d) The sealing end supporting structure and working platform scaffolding shall be effectively bonded to the earth mat.
- (e) Establish bonded earth mat conditions.
- (f) Without removing the earth connection on top of the sealing end, expose the conductor within the top of the sealing end and connect a bonding lead between the conductor and the earth. The bonding lead shall be long enough to pass through the bushing as it is being withdrawn.
- (g) Remove the external oil pipes.
- (h) Without disturbing the bonding lead remove the main earth connection from the top of the sealing end and remove the bushing.
- (i) If it is impossible to comply with step (f) because of the design of the sealing end, the sealing end earth and the bushing may be removed using insulated working conditions. The earth must be replaced as soon as possible and the remainder of the work carried out under bonded earth conditions.

9.6 Terminating a Pilot Cable

9.6.1 Terminating in Pilot Isolation Kiosks

- (a) Check that the insulating rubber floor matting is present and in good condition. Temporary additional matting may be required in order to establish insulated working conditions.
- (b) At all remote terminating points, all conductors shall be isolated from their terminal equipment and all other metallic parts shall be isolated from earth wherever possible.
- (c) A section of the outermost metallic part shall be exposed and then be shrouded with temporary insulating material which will withstand 17kV ac.
- (d) Any other metallic part shall, in turn, be exposed and treated in the same manner until the insulated cores are exposed.
- (e) The exposed core ends shall be insulated from each other as shown below. Where this is not possible an alternative technique can be used provided it ensures the safety of the work party.

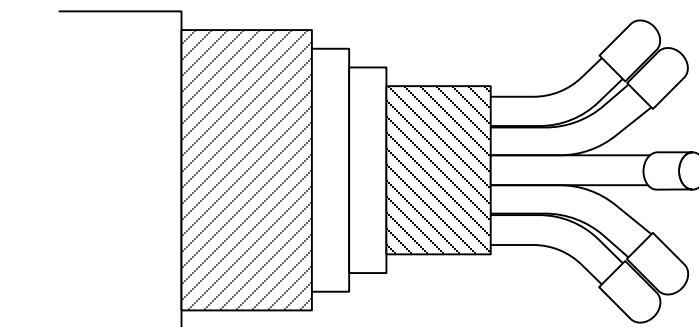

Pilot Cable – Cores Insulated from each other

Warning: A printed copy of this document may not be the current version. Please refer to the Wire to verify the current version.

- (f) Ensure that the plugs on the terminal strips are removed. Treating one core at a time, remove the core insulation and join the core to its terminal strip. Permanently insulate each termination before proceeding to the next.
 - (g) On completion of all terminations remove the temporary insulation over the innermost metallic part.
- Note:** Some metallic parts such as armouring or metallic sheaths are permanently earthed, whereas other metallic parts (such as metallic screens) are deliberately not earthed. Steps (h) to (j) indicate how these permanent earths should be applied.
- (h) Using bonding leads, bond the exposed metallic part to the earth busbar provided in the isolation kiosk. Great care must be taken to ensure that this bonding is carried out by connecting to the earthing board, i.e. not by direct connection.
 - (i) The innermost metallic part may now be permanently earthed to the earth busbar.
 - (j) The bonding leads applied in (h) may now be removed.
 - (k) If permanent earthing of the innermost conductor is not required, then full insulation shall be applied over it.
 - (l) Repeat steps (g) to (k), as appropriate, for all other metallic parts in turn.

9.6.2 Terminating at Locations other than in Isolation Kiosk (including Cable Road Pits)

- (a) Establish insulated working conditions.
 - (b) At all remote terminating points, all conductors shall be isolated from their terminal equipment and all other metallic parts shall be isolated from earth wherever possible.
 - (c) Prepare the cable as detailed in Section 9.6.1 (c) to (e).
 - (d) Establish bonded earth mat conditions.
 - (e) Earth all terminal strips to which connections are to be made and where removable links are provided, ensure that the links are removed.
 - (f) Handling the core by its permanent insulation, remove the temporary insulation and terminate the core on its terminal strip.
 - (g) Terminate all other cores in turn as outlined in (f).
- Caution:** Whereas the terminals in an isolation kiosk are fully shrouded, the terminals at other locations are usually fully exposed. Care must therefore be taken that once a core is terminated, no further personal contact be made with it and another core. A form of temporary shrouding may be necessary.
- (h) Complete the termination of the cable as detailed in Section 9.6.1 (g) to (l).

9.7 Metallic Part Repairs of HV Cables or Pilot Cables

All work must be carried out utilising either bonded earth conditions or insulated working conditions.

The bonded earth conditions method of working shall be the preferred method. The insulated working conditions method would normally only be used for metallic part repairs where the extent of the repairs and the time take to effect the repairs is small.

9.7.1 Metallic Part Repairs Utilising Insulated Working Conditions

- (a) Establish insulated working conditions.
- (b) Expose the outermost metallic part.
- (c) If continuity of the outermost metallic part is already broken because of damage or if continuity has to be broken to effect repairs, a “through bond” shall be established using bonding leads and a earthing board in a similar way to that shown for cutting a pilot cable.

Warning: A printed copy of this document may not be the current version. Please refer to the Wire to verify the current version.

- (d) If the repairs require that more than one metallic part be exposed then the metallic parts must be insulated from each other using material which will withstand 17kV ac.
- (e) Repair the innermost faulty metallic part and apply permanent insulation over it.
- (f) If more than one metallic part was exposed, remove the temporary insulation applied in step (d), effect repairs on the next outermost metallic part and so on.

9.7.2 Metallic Part Repairs Utilising Bonded Earth Mat Conditions

- (a) Prepare the work but in this case use an earthing board with the earth not connected.
- (b) Establish bonded earth mat conditions by connecting an earth to the earthing board and repair the innermost metallic part.
- (c) Change to insulated working conditions by removing the earth connection to the earthing board.
- (d) Using insulated working conditions the bond wire(s) may be removed from the innermost metallic part and full insulation applied.
- (e) If repairs to more than one metallic part are involved, then the remaining metallic parts may be repaired by again reverting to bonded earth mat conditions or by continuing with insulated working conditions.

10. Installation of HV Cables and Pilot Cables

A work method statement shall be produced and approved prior to the installation of HV cables and pilot cables. The work method statement shall utilise the safe working practices in the following sections.

10.1 General

When laying cables into high voltage areas or jointing to cables coming from these areas under disconnected apparatus conditions, attention is drawn to the dangers of electric shock which may arise during a system fault or system switching unless adequate precautions are taken.

During system fault or system switching the potential of the high voltage area earth grid may rise and be transferred via the cable pulling equipment and/or cable conductors or metallic parts of the cable to working parties remote from the high voltage area. Similarly, persons working in high voltage areas connected via pulling equipment and/or cable conductors or metallic parts to remote earth may be in danger.

10.2 Advice to Controller

The controller shall be advised prior to and on completion of pulling operations into HV areas.

10.3 Positioning of Oil Plants and Other Equipment

Where oil plants (or similar items of equipment) are connected to sealing ends or other parts of a cable in a switchyard, then such plants should preferably be located on the switchyard earth mat or, if this is impractical, the oil lines (or other components reaching into the earth mat area) must be provided with an insulating piece, capable of withstanding 17kV ac separating the equipment outside the earth mat area from that within.

10.4 Pulling of HV Cables and Pilot Cables

10.4.1 Cable Pulling Requirements

When pulling a cable between a live high voltage area and an external joint bay it is essential that precautions, such as those listed below, are taken to prevent transfer of potential as described in section 7.1.

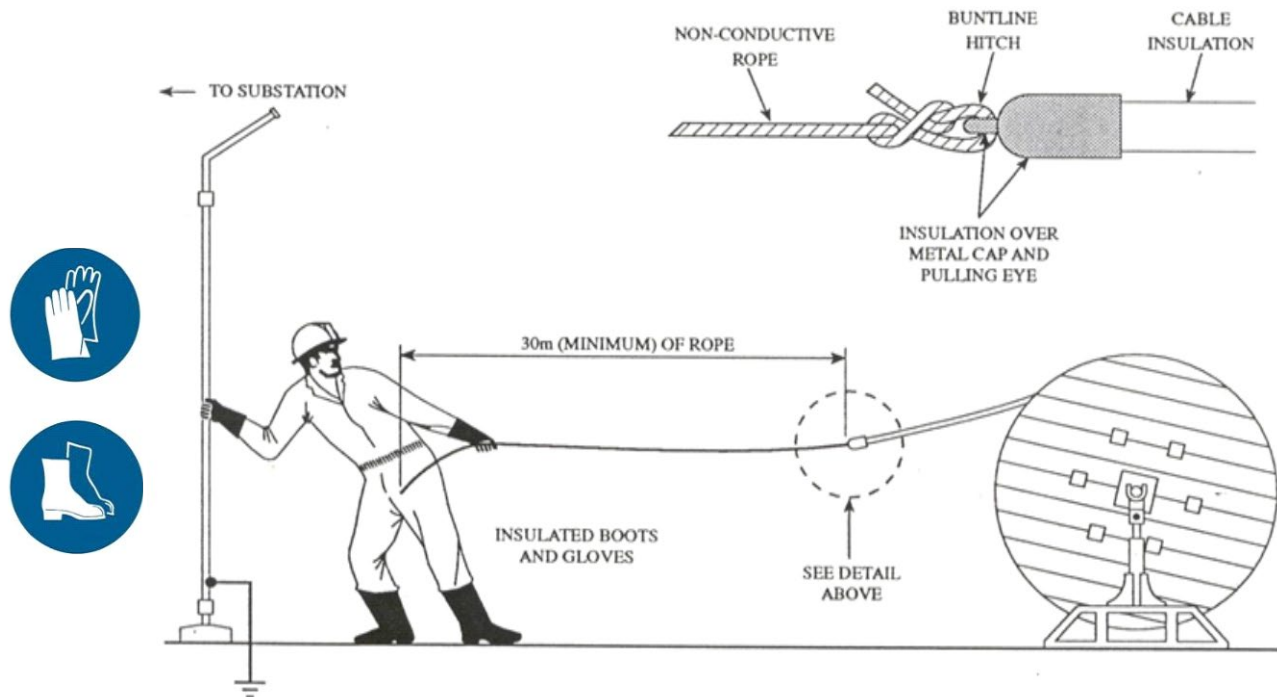

Pulling Cable into Substation

- Bare conductive equipment such as steel wire ropes shall not be used within 30 meters of the substation earth mat.
- Due to the presence of a conducting graphite coating on power and pilot cables, workers must work under insulated conditions, i.e. suitably approved insulated footwear and gloves must be worn and care must be taken to ensure that the cables does not come into contact with exposed parts of the body.

Pulling shall be carried out by one of the following methods or alternatively a specific work method developed for the work which addresses the transfer potential risk. :

Method 1:

The cable drum shall be set up in a position not less than 30 metres from the high voltage boundary fence and the cable pulled in a direction away from the fence using conventional equipment and methods. When just sufficient cable is left on the drum to reach the station sealing end pulling shall cease.

OR

Method 2:

The cable can be pulled towards and into the high voltage area providing a suitably sized non-conductive rope is used in the area extending 30 metres from the boundary fence and provided all exposed metallic parts are insulated to withstand 17kV ac.

OR

Method 3:

The cable drum shall be set up inside the substation area and the cable pulled to a distance not less than 30 metres beyond the high voltage boundary fence using a suitable sized non-conductive minimum stretch rope. Any exposed metallic parts on the nose of the cable must be fully insulated to withstand 17kV ac.

Note: it is essential for control of the pulling operation and for safety of workers and equipment that minimum stretch rope is used.

Warning: A printed copy of this document may not be the current version. Please refer to the Wire to verify the current version.

At the 30-metre point a steel wire rope may be used to complete the pull provided that at least 2 metres of non-conductive rope is used between the cable pulling eye and the steel wire rope and the metallic parts on the nose of the cable are fully insulated to withstand 17kV ac.

10.4.2 First Joint Bay-Insulation of Cable Metallic Parts

The cable metallic parts and all oil supplies to the cable shall be fully insulated in the first joint bay external to the high voltage area as soon as practicable after the cable pulling and before the insulation is removed from the end of the cable within the high voltage area.

To ensure the adequacy of the applied insulation and the absence of damage to the cable sheath, a serving test of 17kV ac shall be applied between the cable sheaths.

10.4.3 Cable Sealing Ends – Working Methods

The cable shall be terminated in the cable sealing ends working under either insulated working conditions or bonded earth mat conditions as determined by an engineering assessment.

10.4.4 Cable Sealing Ends – Isolation from Substation Earth

On completion of terminating the sealing ends and where further work is to be performed in remote joint bays, the following conditions shall be established at the sealing ends.

- (a) The sealing end cap and the cable metallic sheath shall be bonded together and insulated from the high voltage area earth grid by sufficient insulation to withstand 17kV ac.
- (b) Warning signs shall be fixed to the sealing end support structures warning of the possible existence of capacitive voltages and directing that the sealing ends must not be connected to earth or the high voltage system.

Note: The sealing end can still be considered as disconnected apparatus, provided sufficient insulation, delineation and labelling is provided.

10.4.5 Field Jointing

Working methods will depend on field conditions and will be determined by the engineer in charge. When a section of the cable has been connected to a terminal station all further work on that section shall be carried out in accordance with Section 9.2.

10.5 Pilot Cable Terminations and Jointing

All field jointing shall preferably be carried out before the ends are terminated within the high voltage area. During this operation, the ends within the high voltage areas shall have all metallic parts insulated to withstand 17kV ac and field jointing shall be carried out under insulated working conditions.

Terminating within the high voltage areas shall be carried out in accordance with Section 9.6. If termination of the pilot is required in advance of jointing along the route, then termination shall be made in accordance with Section 9.6 and all subsequent jointing shall be carried out as detailed in Section 9.2.1.

11. Accountability

Responsible person	Responsibility
Head of HSE	Maintenance and ownership of this work instruction
Manager – Training	Implementation of the training impacts of this work instruction
Authorised persons	Comply with this work instruction

Warning: A printed copy of this document may not be the current version. Please refer to the Wire to verify the current version.

12. Implementation

This procedure is to be implemented in conjunction with the implementation of TransGrid's Power System Safety Rules. It will be available as a resource, published on the Wire.

13. Monitoring and Review

The Head of HSE is responsible for the ongoing monitoring and review of the documents associated with the Power System Safety Rules. This can include but is not limited to:

- Requesting regular feedback on the effectiveness of procedures and work instructions. Appropriate feedback tools include focus groups and online assessments;
- Where a change has occurred in our processes; and
- Recommendations arising from incidents.

14. Change from previous version

Revision no	Approved by	Amendment
0	Lionel Smyth, EGM/Network Services & Operations	> Replaces GD SR G2 006 R2 "Safe Working Practices on High Voltage Transmission Cables"
1	K McCall, Manager Health, Safety & Environment	> Revised accountability for this work instruction; > Reference to Access Authority updated to Cable AA or Cable Testing AA where relevant; > Hazardous Situations table summarised
2	M Gatt, EM, Works Delivery	> Work Instruction updated to new template > References to Gas cables and systems removed > HV Transmission Cable definition changed to start at 22kV rather than 132kV to more accurately represent TransGrid's installed cables. > Minor clarifications throughout > Greater allowance and reference made to the fact that work methods and controls will vary depending on manufacturer and cable type. > Insulating rating requirements changed from 15kV to 17kV ac > Defined terms reduced to remove obvious inclusions > 4.2.2 Wording updated to better align with access procedures > 6.1 – Overall earth resistance to be 10 Ohms > Figures updated to include more relevant terminology > 7.1 updated to required identification through signal injection to be via inductive coupling > 7.2 (b) existing content removed, replaced by new alternative, (d) updated and (g) added. > Existing section 9.1 removed and replaced by a more high level guidance > Existing 9.2 moved to Appendix G. 9.2 now refers workers to manufacturer and cable type specific requirements > Plug board replaced by earthing board throughout

Warning: A printed copy of this document may not be the current version. Please refer to the Wire to verify the current version.

		<ul style="list-style-type: none"> > Appendix A dated content removed, new content added. > Appendix B dated content removed, new content added. > Appendix D dated content removed, new content added.
--	--	---

15. Reference Documents

Document
Power System Safety Rules
Access for Work on High Voltage Transmission Cables
Work on Disconnected Apparatus
Access for work on LV/MECH Apparatus

16. Attachments

- > Appendix A – Insulating Materials and Equipment
- > Appendix B – Earthing & Bonding Clamps and Leads
- > Appendix C – Isolating Transformers, Instrument Transformers and Testing Equipment
- > Appendix D – Earth Stake and Cable Spike
- > Appendix E – Earthing board
- > Appendix F – Induced Voltages
- > Appendix G – Making a Joint in a HV Cable - Example

Warning: A printed copy of this document may not be the current version. Please refer to the Wire to verify the current version.

Appendix A – Insulating Materials and Equipment

A.1 Insulated Platforms, Sheets or Mats

Insulating sheets shall be either Neoprene or EPDM rubber to Class 2 (17kV) from IEC 61111

SWMS involving use of these items should consider:

- Cleanliness requirements;
- Installation location for step potential;
- Installation/Environment requirements;
- Checks for potential damage due to wear and tear and heat;
- Potential for reduced effectiveness due to movement;
- Risk of moisture contamination;
- Prior use inspection for cuts and tears; and
- Testing requirements (6 monthly)

A.2 Insulated Gloves and Footwear

Insulated gloves and Footwear shall be:

- Manufactured, tested and stored in accordance with recognised standards.
- They shall be appropriately rated, both mechanically and electrically for the task to be performed.
- They shall be inspected immediately prior to use to ensure they are in suitable condition to perform the work.

IEC 60903 is currently used as the standard for insulating gloves

Appendix B – Earthing & Bonding Clamps and Leads

For the attachment of an earth lead or bond lead to a sheath, core, etc., a bonding cable shall be used which has clamps which:

- (a) Are of adequate mechanical strength to support the attached earth lead or bonding lead; and
- (b) Can be tightened to produce a stable and effective contact between the clamp and the core or sheath surface.

The earthing leads or bonding leads shall be made of a conductor of minimum size 16mm² copper equivalent.

SUPERSEDED

Warning: A printed copy of this document may not be the current version. Please refer to the Wire to verify the current version.

Appendix C – Isolating Transformers, Instrument Transformers and Testing Equipment

Isolating Transformers

To ensure that remote earth potentials are not transferred to the worksite, all electrically operated portable tools, lead lamps, etc., shall be supplied from an isolating transformer which electrically separates the incoming power supply and its earth system from the power supply to the worksite. The isolating transformer shall:

- (a) Provide an insulating barrier between its input and output windings and between output windings and case and core which will withstand 17kV ac.
- (b) Have its core and case earthed to the “supply side” earth.
- (c) The secondary winding of the isolating transformer shall supply only the load that is within the confines of the bonded earth mat working area. Secondary terminals, and cabling (up to at least the edge of the bonded earthmat) shall be insulated to withstand 17kV ac or delineated to ensure it cannot be touched.

Note: any electrical plant or equipment used on the bonded earth mat which requires earthing must have its earth lead connected to the local earth stake. In all other cases earth leads of electrical plant and/or equipment shall be earthed in accordance with the SAA Wiring Rules. Where possible, RCD/earth leakage protection devices shall be used.

Instrument Transformers and Testing Equipment

All instrument and testing equipment shall conform to and be used in accordance with one of the following conditions:

- (a) All internal circuit components shall be completely covered by a rigid case from which they are insulated. The insulation between the circuit components and the case shall be capable of withstanding 17kV ac.

All terminals for connection of external test leads and control adjustments, range switches and the like, shall be covered by an insulation which will withstand 17kV ac.

Such equipment may be operated under bonded earth mat conditions or insulated working conditions.

Under bonded earth mat conditions no connection or disconnection of this equipment shall be made to the cores or sheaths unless these cores or sheaths are earthed.

- (b) For mains power test equipment, all internal circuits shall be enclosed in a metallic case which is fitted with an earth terminal. The earth connection between the earth terminal and the earth stake shall be a stranded conductor not less than 4mm² or equivalent.

All terminals for connection of external test leads and the external sections of control adjustments, range switches, movement adjusting screws and the like shall be covered by insulation which will withstand 17kV ac.

Such equipment may be operated under bonded earth mat conditions provided that:

- i. If it has a metallic case, of the instrument is bonded to the local earth stake prior to making any connections from the instrument to any cable sheath or core.
- ii. The connection bonding the metallic case to the local earth stake is not removed whilst the instrument is connected to a cable sheath or core.

If no special case or high voltage insulation is provided, the equipment shall only be used whilst working under insulated working conditions.

The operator of the equipment must ensure that personal contact is made with only one conducting part of the instrument at any time. This will enable operation of instrument controls, such as range switches, but will not permit making or breaking of connections.

Warning: A printed copy of this document may not be the current version. Please refer to the Wire to verify the current version.

High voltage insulating links or jacks must be used in test leads. Such links or jacks shall be capable of withstanding 17kV ac both across the opened link and from conductive parts (including operating handle or plug) to earth.

Earthing of a high voltage cable section or sheath shall be via a discharge resistor and shall be applied under insulated working conditions, usually incorporated into the handle and insulated to 17kV.

SUPERSEDED

Warning: A printed copy of this document may not be the current version. Please refer to the Wire to verify the current version.

Appendix D – Earth Stake and Cable Spike

Earth Stake

The standard earth stake shall at a minimum be a copper clad steel earthing rod (1.4m x 13mm) with a clamp arrangement suitable for 16mm² conductor.

Cable Spike

TransGrid does not have standard cable spiking equipment. Appropriate equipment is to be risk assessed, have work methods prepared and approved for use if required.

SUPERSEDED

Warning: A printed copy of this document may not be the current version. Please refer to the Wire to verify the current version.

Appendix E – Earthing board

The standard earthing board used in TransGrid is a 6mm fixed earth strap with brazed studs with wing nuts (size 12mm). It has a clamp plate for attachment to steelwork and mesh earth mat.

SUPERSEDED

Warning: A printed copy of this document may not be the current version. Please refer to the Wire to verify the current version.

Appendix F – Induced Voltages

A person installing or working on the metallic parts of a HV cable (cores, sheath, armour wires, bonding leads, oil lines, etc.) may be subject to dangerous voltages and electric shock if appropriate working procedures are not followed.

Dangerous voltages due to induced and/or transferred voltage rises may occur even though the cable is isolated from the electrical system and solidly connected to earth.

It is important to understand that whilst it may be perfectly safe to work on an out of service HV cable under normal system conditions, dangerous voltages can occur expectantly at any time as a result of:

- Faults on the main electrical system
- System switching or other voltage surges
- Lightning strikes, etc.

It is important to carefully consider the voltages that may appear on an HV cable and determine the correct safe working methods to be employed before any work is undertaken.

Transferred Voltage Rise Conditions

Under system earth fault or system switching conditions, large currents can flow via the earthing system to the supply transformer. As the earthing system has a definite resistance to true (or remote) earth, the passage of current through this resistance will cause the earthing system and all conductors connected to it, to rise in voltage relative to true earth. Where the conductors connected to the earthing system are insulated too, rise will be transferred along the insulated conductor.

The figure below illustrates the path formed when a conductor is connected between a remote earth and a substation earth mat.

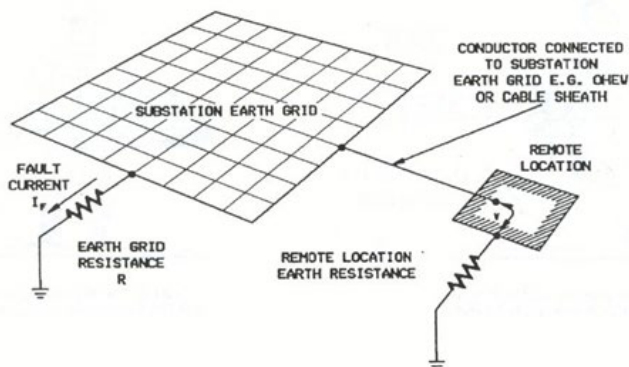

IN THE EVENT OF A 10,000 AMP FAULT AT A SUBSTATION WHOSE EARTH GRID RESISTANCE R IS 0.1 OHM THE VOLTAGE TO GROUND AT A REMOTE LOCATION WOULD BE 1,000 VOLTS (10,000 AMP \times 0.1 OHM)

TRANSFERRED EARTH GRID POTENTIAL

Also the sharing of earth return fault current by the metallic sheath or armour wires, where applicable, of a HV cable will result in a voltage rise on the sheath or armour wires relative to true earth.

Transferred voltage rises can also occur on insulated conductors as a result of direct contact between overhead power circuits or lightning strikes.

If a cable is connected to a section of overhead line it is advisable not to work on insulated conductors if lightning activity is anticipated or present.

Induced Voltage Conditions

Current flowing in fully insulated power cable systems, overhead or underground, may give rise to induced voltages in nearby parallel fully insulated power or supervisory cables. For example, an overhead power line one or two streets away from a parallel fully HV cable system may give rise to unacceptably high induced voltages in the cable.

There are two main types of induced voltages:-

- Electrostatic (Capacitive), and
- Electromagnetic

Electrostatic (Capacitive) Induction

Where a conductor is located within the electric field of an energised conductor, an electrostatic voltage will be induced in the conductor.

The voltage due to electrostatic induction is constant along the conductor and the application of an earth to an otherwise insulated conductor will effectively drain the charge from the conductor and reduce it to earth potential. The application of multiple earths will not result in circulating currents.

Electromagnetic Induction

Where a conductor is located within the varying magnetic field of an energised conductor carrying alternating current, an electromagnetic voltage will be induced in the conductor.

These electromagnetically induced voltages are commonly referred to as low frequency induction.

The voltage due to electromagnetic induction appears as a difference in potential between the ends of the conductor and the application of an earth to one end of an otherwise insulated conductor will result in a potential above earth at the remote end. The application of a further earth at the remote end will result in a circulating current in the conductor.

If a conductor subject to electromagnetic induction and earthed at both ends is cut, a voltage will appear across the cut ends of the conductor. This can be avoided by placing a bonding conductor across the proposed cut position prior to cutting the cable.

Under power system fault conditions heavy fault current will flow for the period taken for the protection equipment to open the faulty circuit. These heavy currents can give rise to very high electromagnetic induced voltages in adjacent parallel conductors (and metallic cable sheaths and armouring).

Unacceptably high electromagnetically induced voltages can occur from adjacent circuits carrying normal load current. The magnitude of the induced voltage is dependent upon separation of the circuits, lengths for which the circuits are parallel and magnitude of the local current

Shielding Effects

Electromagnetically induced voltages can be reduced if there is another conductor in the vicinity that is connected to earth in at least two locations that would allow an opposing current can circulate. The amount of shielding provided depends on the number and spacing of these conductors.

The conductors of a metal sheathed cable with porous textile servings are effectively shielded as the cable is continuously earthed through saturated/non-insulating servings. However, metallic sheathed cables with a plastic serving are not effectively shielded unless the metal sheath is earthed at both ends.

Appendix G – Making a Joint in a HV Cable - Example

The following steps provide an example of how a joint may be performed. Techniques and necessary safety controls will vary depending on the manufacturer and cable type and those specific considerations must be considered when the safe work method for the work is being developed.

- (a) Prepare each cable end in turn as outlined in Section 6.1.1, the ends being bonded as shown in the following figure.

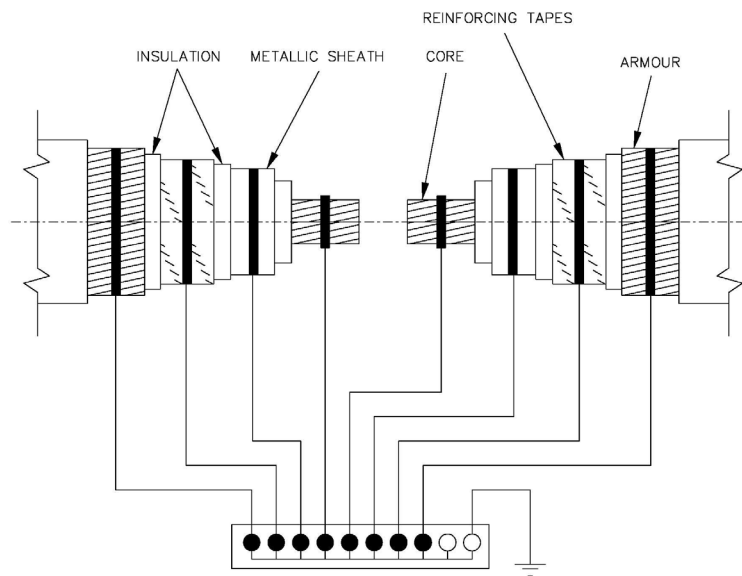

HV CABLE WITH METALLIC PARTS AND CORE BONDED TO EARTH

- (b) Continue with bonded earth mat conditions.
- (c) Apply a conductor calliper clamp to the core as close as possible to the insulation on either side of the loose ferrule. The conductor earth clamps applied previously can now be removed as shown in below.

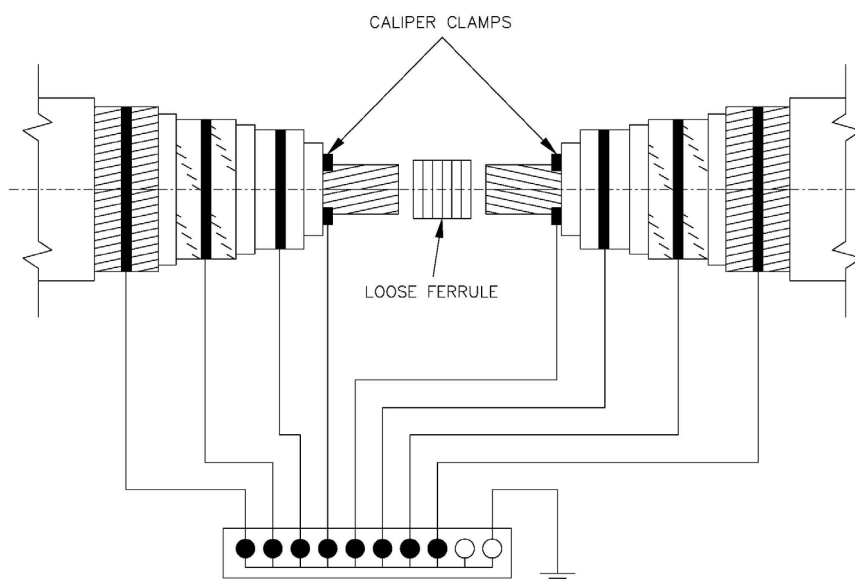

HV CABLE WITH CALIPER CLAMPS APPLIED TO CORE

- (d) Join the cores of the cable ends together by compressing the ferrule.

Warning: A printed copy of this document may not be the current version. Please refer to the Wire to verify the current version.

(e) Using bonding leads apply an earth to the ferrule via the earthing board. The calliper clamps applied in step (c) can now be removed as shown in below.

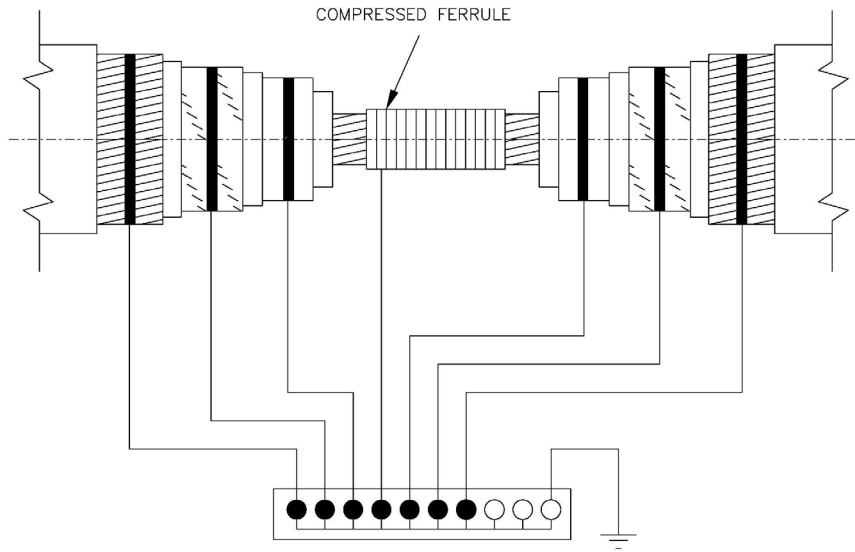

HV CABLE WITH COMPRESSED FERRULE APPLIED TO CORE

- (f) Establish insulated working conditions at the worksite.
- (g) Temporary insulating material, which will withstand 17kV ac, shall be applied over the exposed metallic parts but not over the core.
- (h) Break continuity of the earth connection to the ferrule by removing the appropriate connection on the earthing board. The earth clamp on the ferrule may now be removed.
- (i) Apply insulation to the core until at least 3mm radial thickness of insulation has been applied to the joint.
- (j) Re-establish bonded earth mat conditions. The temporary insulation applied in step (g) may now be removed.
- (k) Proceed as follows:
 - i) For uninsulated and poorly insulated metallic sheath systems continue jointing under bonded earth mat conditions until contact with metallic parts is no longer necessary. This will usually last until the final attachment of the permanent earth connection or to the start of the bitumen filling of the coffin.
 - ii) For fully insulated and/or cross-bonded systems where joints have no cross-bonding or earth connection facilities continue under bonded earth mat conditions until the temporary earth connection must be removed to complete joint insulation. At this stage insulated working conditions must be set up and employed until sheath insulation is completed.
 - iii) For fully insulated and/or cross-bonded systems where joints have cross-bonding or earth connection facilities, permanent bond leads are attached to the sleeve. The temporary sheath earth can then be removed and the sheath insulation completed after the permanent bond leads are earthed. Where the permanent bond leads are connection to an earth stake rather than the permanent link box, insulated working conditions must be set up to remove the bond leads from the earth stake. The exposed ends of the bond leads must be insulated to 17kV. Subsequent work on these leads must be carried out under insulated working conditions. Alternatively, the bond leads may be spiked and work carried out under bonded earth mat conditions.

Warning: A printed copy of this document may not be the current version. Please refer to the Wire to verify the current version.