

Typical Secondary Systems Overview

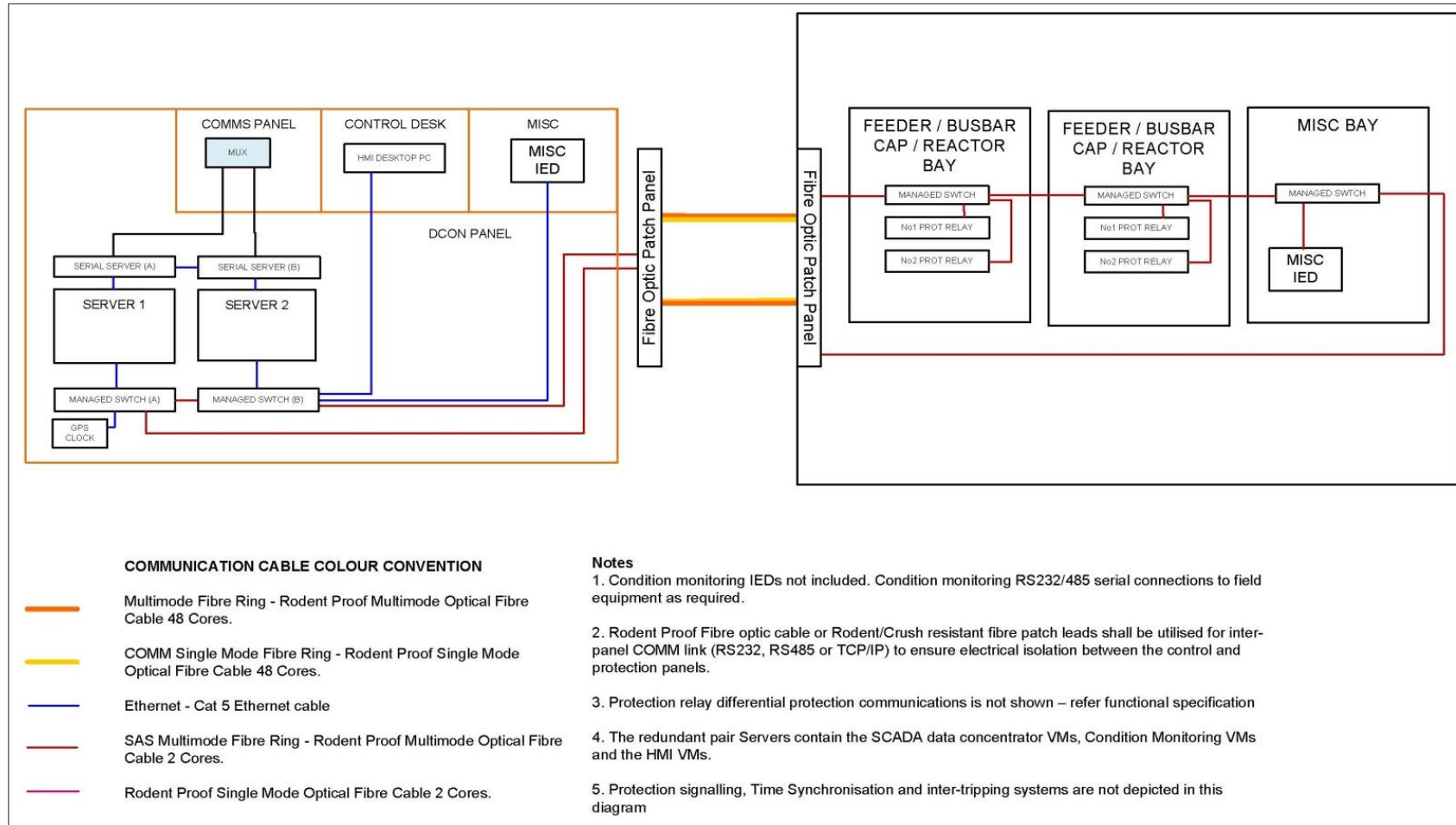

This drawing is copyright and is the property of TransGrid and is subject to the terms and conditions of TransGrid's website.